

LB-LE SERIES
LOAD MEASURING PINS
USER MANUAL



While every precaution has been exercised in the compilation of this document to ensure the accuracy of its contents, MAGTROL assumes no responsibility for errors or omissions.

Additionally, no liability is assumed for any damages that may result from the use of the information contained within this publication.

COPYRIGHT

Copyright ©2000–2021 Magtrol, Inc. & Magtrol SA. All rights reserved.

Copying or reproduction of all or any part of the contents of this manual without the express permission of Magtrol is strictly prohibited.

TRADEMARKS

National Instruments™, LabVIEW™ and NI-VISA™ are trademarks of National Instruments Corporation.

Microsoft® and Windows® are registered trademarks of Microsoft Corporation.

SAFETY PRECAUTIONS

**WARNING**

WARNING! IN ORDER TO MINIMIZE RISKS, IT IS OF UTMOST IMPORTANCE TO RESPECT THE CURRENT SAFETY STANDARDS WHEN PLANNING, CONFIGURING AND OPERATING A LOAD-FORCE-WEIGHT SYSTEM OR INSTALLATION.

**WARNING**

WARNING : THE INSTALLATION AND THE CALIBRATION IS RESERVED TO THE QUALIFIED STAFF. PLEASE CONSULT THIS MANUAL BEFORE ANY MANIPULATION AND FOLLOW ATTENTIVELY THE INSTRUCTIONS.

**CAUTION**

CAUTION! OPERATE THE LB-LE SERIES LOAD MEASURING PINS WITH GREAT CAUTION! THE SENSOR MAY BE IRREVERSIBLY DAMAGED IF IMPACTED MECHANICALLY (FALL), CHEMICALLY (ACIDS) OR THERMALLY (HOT AIR, VAPOR).

1. Make sure that all electronic products from Magtrol (or third party suppliers) are earth-grounded, to guarantee personal safety and proper operation.
2. Check line voltage before operating electronic equipment.
3. The calibration requires to observ securized electrical working methods.
4. The cabling must be done with power supply switched off
5. Periodically check all connections and attachments.
6. In case of rotating elements, ensure that all rotating parts are equipped with appropriate safety guards.
7. Always wear protective glasses when working close to rotating elements.

QUALIFIED PERSONNEL

Persons in charge of installing and operating the LB-LE Series Load Measuring Pins must have read and understood this user manual, paying extra close attention to all safety-related information.

The LB-LE Series Load Measuring are a high-precision product integrating recognized and long-proven measurement techniques, mainly strain gauge measurements. The sensor can give rise to residual dangers if used and manipulated in a non-compliant way by unqualified personnel.

This Load Pins must be handled by qualified personnel according to the technical requirements and the above-mentioned safety instructions. This is also true when using load measuring pins accessories.

TABLE OF CONTENT

SAFETY PRECAUTIONS	C
TABLE OF CONTENT	V
PREFACE	VII
1. INTRODUCTION	1
1.1 GENERAL DESCRIPTION	1
1.2 LB-LE - LOAD PINS RANGE PRESENTATION	1
1.3 DATASHEET	2
1.3.1 LB Series - Load Measuring Pins	2
1.3.2 LE Series - Load Measuring Pins	10
2. INSTALLATION / CONFIGURATION	21
2.1 MOUNTING THE LOAD MEASURING PINS	21
2.1.1 General mounting instructions	21
2.1.2 Pin holder key	23
2.1.3 Positioning of the load measuring pin	24
2.2 EXTRACTION OF THE LOAD MEASURING PINS	26
2.2.1 Extraction of large size load pins using an extraction device (LB/LE 218 - 221, LB 238 - LB 241, LE 418 - LE 421 and LE 618 - LE 621)	27
2.2.2 Extraction of small size load measuring pins	28
2.2.3 Extraction of load measuring pins ON bearings	28
2.3 CONNECTION OF THE LOAD MEASURING PINS	29
2.3.1 Connection of a load measuring pin to any instrument	30
2.3.2 Connection of a load measuring pin LB series to LMU series (load monitoring unit)	36
2.3.3 Connection of a load measuring pin to AN 1500 M (digital display monitor)	37
2.3.4 Connection of a load measuring pin to AN 2000 C (digital signal conditioner / monitor)	39
2.3.5 Connection of a load measuring pin to GAD series (large digital display)	40
3. OPERATING PRINCIPLES	43
3.1 MEASUREMENT PRINCIPLE	43
3.2 STRAIN GAUGES	44

3.3 CHECKING OF THE APPLIED LOAD	45
3.3.1 LB Series load measuring pins	45
3.3.2 LE series load measuring pins	46
3.4 B.I.T.E. TEST FUNCTION FOR LE 4XX & LE 6XX SERIES	47
4. INFLUENCE FACTORS	49
4.1 INFLUENCE OF THE LOAD PIN ORIENTATION	49
4.1.1 LB Series, load pins orientation	50
4.1.2 LE Series, load pins orientation	51
4.2 INFLUENCE OF THE APPLIED FORCE	52
5. MAINTENANCE, REPAIR & CALIBRATION	53
5.1 MAINTENANCE	53
5.1.1 LUBRICATION	53
5.2 CALIBRATION	53
5.3 REPAIR	54
6. TROUBLESHOOTING	55
6.1 TROUBLESHOOTING ON LB SERIES	55
6.2 TROUBLESHOOTING ON LE 2XX SERIES	55
6.3 TROUBLESHOOTING ON LE 4XX AND LE 6XX SERIES	56
APPENDIX A : OIML CERTIFICATION	57
SERVICES INFORMATION	59
RETURNING EQUIPMENT TO MAGTROL INC. (UNITED STATES)	59
RETURNING EQUIPMENT TO MAGTROL S.A. (SWITZERLAND)	60
REVISIONS TO THIS MANUAL	61

PREFACE

PURPOSE OF THIS MANUAL

This manual contains all the information required for the setup, connection and general use of Magtrol's LB-LE Load Measuring Pins. To achieve maximum capability and ensure proper use, please read this manual in its entirety before operating the unit. Keep the manual in a safe place for quick reference whenever a question should arise.

WHO SHOULD USE THIS MANUAL

This manual is intended for those who install load measuring pins for lifting or weighing installations and connect them to electronic signal processing systems to carry out measurements. The operator is assumed to have the necessary technical training in mechanical engineering and electronics to enable him to install these load measuring pins.

MANUAL ORGANIZATION

This section gives an overview of the structure of the manual and the information contained within it. Some information has been deliberately repeated in different sections of the document to minimize cross-referencing and to facilitate understanding through reiteration.

The structure of the manual is as follows:

- Chapter 1: **INTRODUCTION** – Contains the technical data sheets for the load measuring pins, which describe the units and provide an overview of their possible applications.
- Chapter 2: **INSTALLATION / CONFIGURATION** – Provides the information needed for the setup and connection of the load measuring pins.
- Chapter 3: **OPERATING PRINCIPLES** – Describes the load measuring pins measuring principle.
- Chapter 4: **INFLUENCE FACTORS** – Contains explanations concerning the influence of the mounting position of the load measuring pins on the measured signals.
- Chapter 5: **MAINTENANCE, REPAIR & CALIBRATION** – Contains information on lubrication procedures and provides recommendations for the calibration and checking of the measuring current and voltage.
- Chapter 6: **TROUBLESHOOTING** – Provides solutions to common problems encountered during configuration and running of the load measuring pins.
- Chapter 7: **SERVICES INFORMATION** – Information, contacts and addresses relative for repair and/or calibration.
- Appendix: **APPENDIX A : OIML Certification** – OIML Certificate (for certain LB 230 Series Load Measuring Pins)

SEMANTICS

In this manual, different terminologies are used to speak about the «Load Measuring Pins». The primary purpose is to make this user manual useful and easily readable.

Below are the different terminologies used: «Load Measuring Pin», «Measuring Pins», «Load Transducer», «Transducer» and «Load Pin» are synonyms; «LX XXX Series» is an abbreviation for «LX XXX Series Load Measuring Pins», etc.

The term «Series» stand for all the products of the series (e.g. LE 4XX Series refers to LE 400 to LE 499).

CONVENTIONS USED IN THIS MANUAL

The following symbols and type styles may be used in this manual to highlight certain parts of the text:



NOTICE

INDICATES INFORMATION CONSIDERED IMPORTANT BUT NOT HAZARD RELATED.

THIS IS INTENDED TO DRAW THE OPERATOR'S ATTENTION TO COMPLEMENTARY INFORMATION OR ADVICE RELATING TO THE SUBJECT BEING TREATED. IT INTRODUCES INFORMATION ENABLING THE CORRECT AND OPTIMAL FUNCTION OF THE PRODUCT.



CAUTION

INDICATES A HAZARDOUS SITUATION THAT, IF NOT AVOIDED, COULD RESULT IN MINOR OR MODERATE INJURY.

THIS IS ALSO USED TO DRAW THE OPERATOR'S ATTENTION TO INFORMATION, DIRECTIVES, PROCEDURES, ETC. WHICH, IF IGNORED, MAY RESULT IN DAMAGE TO THE MATERIAL BEING USED. THE ASSOCIATED TEXT DESCRIBES THE NECESSARY PRECAUTIONS TO TAKE AND THE CONSEQUENCES THAT MAY ARISE IF THESE PRECAUTIONS ARE IGNORED.



WARNING

INDICATES A HAZARDOUS SITUATION THAT, IF NOT AVOIDED, COULD RESULT IN DEATH OR SERIOUS INJURY.

THIS INTRODUCES DIRECTIVES, PROCEDURES, PRECAUTIONARY MEASURES, ETC. WHICH MUST BE EXECUTED OR FOLLOWED WITH THE UTMOST CARE AND ATTENTION, OTHERWISE THE PERSONAL SAFETY OF THE OPERATOR OR THIRD PARTY MAY BE AT RISK. THE READER MUST ABSOLUTELY TAKE NOTE OF THE ACCOMPANYING TEXT, AND ACT UPON IT, BEFORE PROCEEDING FURTHER.



DANGER

INDICATES A HAZARDOUS SITUATION THAT, IF NOT AVOIDED, WILL RESULT IN DEATH OR SERIOUS INJURY. THE SIGNAL WORD «DANGER» IS TO BE LIMITED TO THE MOST EXTREME SITUATIONS.

THIS INTRODUCES DIRECTIVES, PROCEDURES, PRECAUTIONARY MEASURES, ETC. WHICH MUST BE EXECUTED OR FOLLOWED WITH THE UTMOST CARE AND ATTENTION, OTHERWISE THE PERSONAL SAFETY OF THE OPERATOR OR THIRD PARTY MAY BE AT RISK. THE READER MUST ABSOLUTELY TAKE NOTE OF THE ACCOMPANYING TEXT, AND ACT UPON IT, BEFORE PROCEEDING FURTHER.

The safety symbol may subsequently vary depending on the source of the hazard. Below are examples:



Various safety pictograms according to ISO 7010

1. INTRODUCTION

1.1 GENERAL DESCRIPTION

When the force applied to mechanical structures needs to be measured, expensive modifications to the structure are often necessary. Load measuring pins present considerable advantages, since they replace conventional force transducers and at the same time are easily integrated into a measurement system. They are used in replacement of non-instrumented load-carrying pins.

As a solution to load measuring problems MAGTROL proposes a wide range of products dedicated to load measuring and overload protection:

- LB 210 - LB 221 : standard models
- LB 231 - LB 241 : enhanced models for use in hostile environments
- LE 2XX Series: models with calibrated current output.
- LE 4XX Series : models with calibrated current output and B.I.T.E monitoring.
- LE 6XX Series : models with redundant calibrated current output and B.I.T.E monitoring.

1.2 LB-LE - LOAD PINS RANGE PRESENTATION

All LB & LE Series Load Measuring Pins are mainly made of stainless steel body. The electronic components (strain gauges) necessary for the measurement of the shear force are located inside the body. The strain gauges consist of a single full strain gauge bridge or a double redundant bridge.

A signal processing electronics is added inside or outside the strain gage shaft and a connector allows cable connection to the signal processing electronics. For this purpose, LE & LU Load Measuring Pins are often linked to Magtrol's LMU Series - Load Monitoring Units. These signal conditioners are specially dedicated for strain gauge sensor applications. They provide the excitation voltage, amplify the output signal, and incorporate overload protection.



Fig.1-1 LE 4XX & LE 6XX Load Measuring Pins.



Fig.1-2 LMU217 Load Monitoring Unit

1.3 DATASHEET

1.3.1 LB SERIES - LOAD MEASURING PINS

LB SERIES

LOAD MEASURING PINS

LB Series Load Measuring Pins can be used alone or as part of a complete measurement system. Magtrol offers a wide range of Load-Force-Weight Transducers in various executions and accuracy classes and our Load Monitoring Units (LMUs) constitute an ideal safe measurement system which continuously checks for overloads and short circuits.

FEATURES

- For overload detection and load measurement from 2.5 kN to 1250 kN (0.28 tf to 140.5 tf).
- Admissible Overload: 150 % of the nominal load.
- Overload at Rupture: up to 500 % of the nominal load.
- Insensitive to external mechanical and chemical effects.
- Ideal for use in hostile environments.
- Temperature-compensated transducers with strain gauges in full-bridge configuration. On request, available with double bridge redundant.
- Simple installation for cost-saving solutions to measurement problems.
- Many options may be added to the lower-cost standard load pin for greater flexibility.
- Can be designed with special dimensions for adaptation to various construction conditions.
- High reliability for strict safety requirements.

DESCRIPTION

MAGTROL Load Measuring Pins are used to measure load and force and provide overload protection. The pins are mounted into machines in place of normal shafts and fitted with strain gauges, allowing them to produce a signal proportional to the measured load. Manufactured in Switzerland, Magtrol's LB2XX Series Load Pins are rugged with high resistance stainless steel and tight construction, designed specifically for use in harsh industrial environments. Available in several standard ranges from 2.5 kN to 1250 kN, these highly ergonomic pins can be used for either new or refitted installations and are adaptable to various conditions.



Fig. 1: LB210 & LB217 | Load Measuring Pins

APPLICATIONS

When forces acting on mechanical constructions are measured, the additional equipment required can often be costly and difficult to install. Magtrol Load Measuring Pins offer an excellent solution since they act as a direct element in the assembly, replacing a non-instrumented pin or shaft. LB2XX Series Load Pins are used for load measuring devices and overload protection on cranes, hoisting gear, elevators and winches, and force measurement for regulation processes in industrial installations and machinery production. Moreover it is an ideal transducer to detect and measure forces in harsh, tropical, offshore, marine and harbor environments.

DESIGN

The Magtrol Load Pin has 2 circular grooves and an axial bore. Inside the central bore, adjacent to the external grooves, the strain gauges are mounted in a full-bridge configuration (double full-bridge for LB 23X models). The positioning and orientation of the strain gauges have been optimized by means of the finite element method (FEM). Any transverse or axial forces, even when acting on any part of the pin, have practically no influence on the measurement signal.

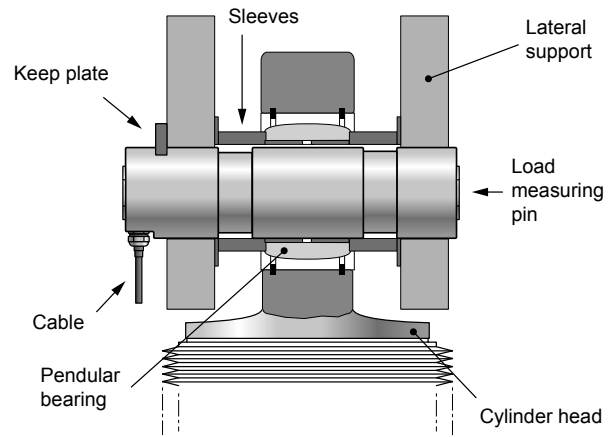

Fig. 2: Mounting example

OPERATING PRINCIPLE

When force is applied to the Load Measuring Pin along its sensitive axis, the effect on the strain gauge bridge results in an output signal proportional to the applied force. The powering of the strain gauge bridge, as well as the amplification of its output signal voltage, is performed by an external amplifier. Depending on the execution, this amplifier allows the monitoring of several levels.

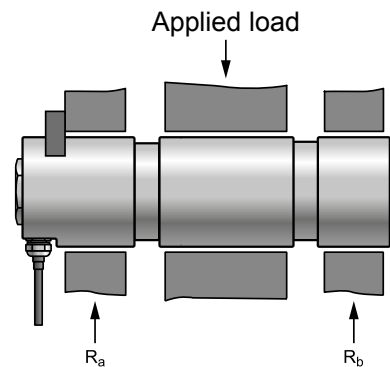
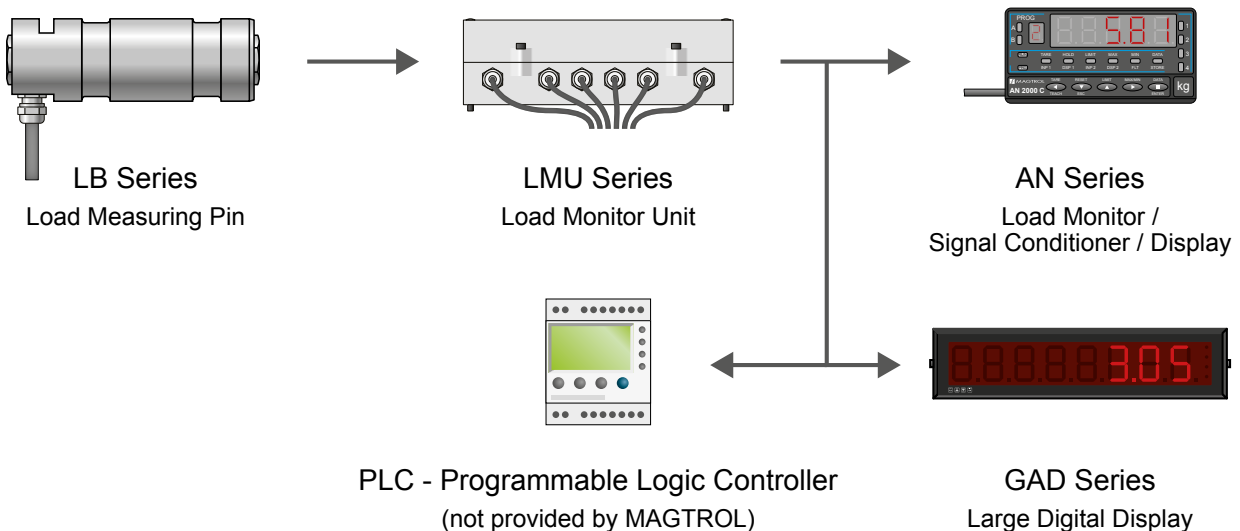
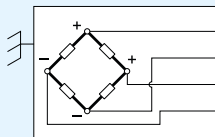

Fig. 3: R_a should equal R_b so that the force is evenly distributed

SYSTEM CONFIGURATION



TECHNICAL DATA - LB 21X SERIES

STANDARD VERSION ^{a)}	LB 210	LB 211	LB 212	LB 213	LB 214	LB 216	LB 217	LB 218	LB 220	LB 221										
LOAD MEASUREMENT																				
Nominal Load (NL) (Metric) ^{b)}	2.5 kN	5 kN	10 kN	20 kN	50 kN	100 kN	200 kN	500 kN	1 000 kN	1 250 kN										
Nominal Load (NL) (US) ^{b)}	0.28 tf	0.56 tf	1.12 tf	2.25 tf	5.62 tf	11.24 tf	22.48 tf	56.2 tf	112.4 tf	140.5 tf										
Overload Admissible (% of NL)	150 % (of nominal load without influence on measurement)																			
Overload at Rupture (% of NL)	≥ 500 %							400 %	300 %											
Non-linearity Error ^{b)}	< 0.25 %							< 0.5 %		< 0.5 %										
Non-linearity + Hysteresis Error ^{b)}	< 0.5 %							< 0.8 %		< 0.8 %										
Repeatability ^{b)}	± 0.1 %																			
MECHANICAL CHARACTERISTICS & ENVIRONMENT																				
Operating Principle	Full-bridge strain gauge																			
Material	Stainless steel 1.4057																			
Lubrication	Not available					Oiler ø4 DIN 3405D or M10 DIN 3405A														
Operating Temperature	-25 °C to +80 °C																			
Storage Temperature	-55 °C to +125 °C																			
Temperature Influence on Zero	± 0.02 % / K																			
Temperature Influence on Sensitivity	± 0.02 % / K																			
Fit	G7 / h6																			
Angle influence on signal output ^{c)}	According to the cosine function																			
Protection Class	IP 66 according to DIN 60529																			
ELECTRICAL CHARACTERISTICS & CONNECTIONS																				
Bridge Impedance Input	400 Ω																			
Bridge Impedance Output	350 Ω																			
Power Supply	5 to 12VDC/AC																			
Zero Adjustment ^{b)}	± 1 %																			
Transducer Sensitivities	0.5 mV/V ± 3 %			1 mV/V ± 3 %				1.8 mV/V ± 3 %												
Output	Integrated 3 m, 6 m, 12 m or 20 m cable Radox K-414 (standard) ^{e)}																			
PG Output	Axial, with heat-shrinkable sleeve					Radial, with heat-shrinkable sleeve (standard); Axial, with heat-shrinkable sleeve (optional)														
Wiring Colors	 <table style="margin-left: 200px;"> <tr> <td>Supply +</td> <td>: red</td> </tr> <tr> <td>Supply -</td> <td>: blue</td> </tr> <tr> <td>Signal +</td> <td>: white</td> </tr> <tr> <td>Signal -</td> <td>: green</td> </tr> <tr> <td>Case / Shield</td> <td>: black</td> </tr> </table>										Supply +	: red	Supply -	: blue	Signal +	: white	Signal -	: green	Case / Shield	: black
Supply +	: red																			
Supply -	: blue																			
Signal +	: white																			
Signal -	: green																			
Case / Shield	: black																			
Output Connector (Optional)	Not available					Radial, connector: Souriau 851 02 E 10 6P50														
Connection Cable Assembly (Optional)	Not available					3 m, 6 m, 12 m or 20 m cable with axial or 90° connector ^{d,e)}														

a) Rating apply to standard load pins only, special models available on request.

b) Of full scale.

c) Variation of the measuring signal due to the angle positioning.

d) Axial connector: Souriau 85106 JC 10 6S50,
90° connector: Souriau 85108 EC 10 6S50.

e) Other longer cables lengths available on request.

DIMENSIONS LB 21X SERIES

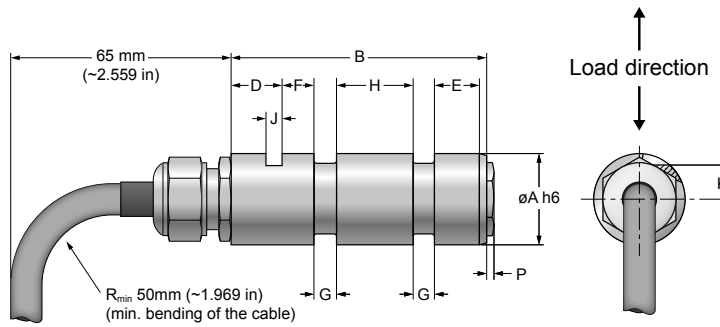

LB 210 - LB 213

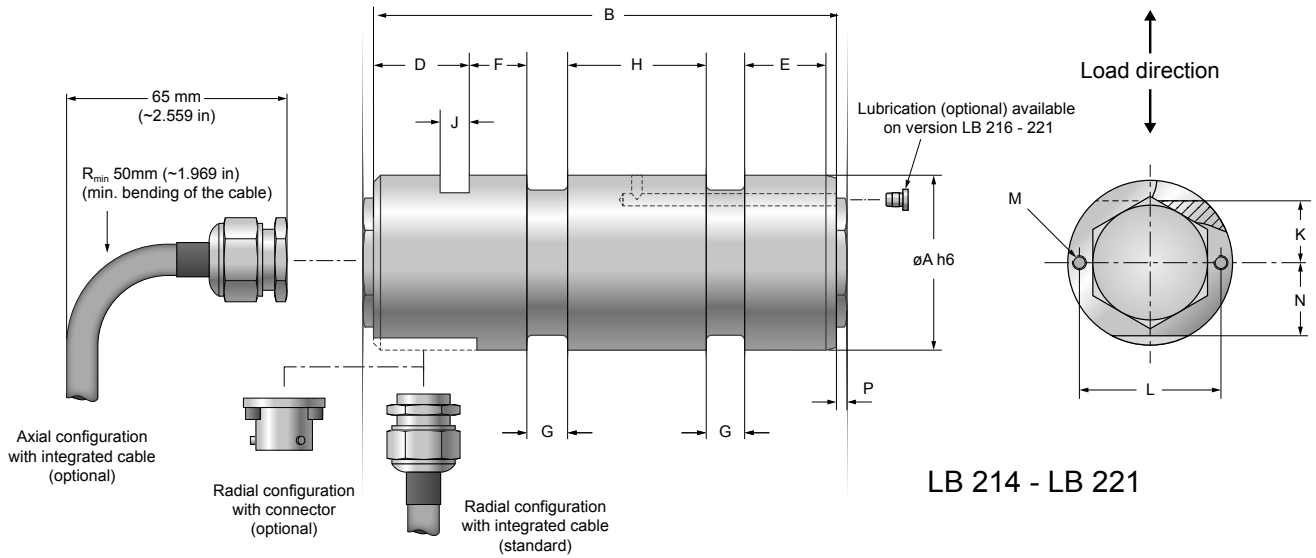

LB 214 - LB 221

NOTE: Original dimensions are in metric units. Dimensions converted to imperial units have been rounded up to 3 decimal places.

MODEL	units	$\varnothing A$	B	D	E	F	G	H	J	K	L	M	N	WEIGHT	
LB210-213	mm	25 h6	84	18	16	10	7	24	5.2	9	N/A	N/A	N/A	0.2 kg	Not available
	in	0.984	3.307	0.709	0.63	0.394	0.276	0.945	0.205	0.354			0.441 lb		
LB214	mm	35 h6	112	25	14	12	12	35	6.3	11.5			16	0.65 kg	
	in	1.378	4.409	0.984	0.551	0.472	0.472	1.378	0.248	0.453			0.630	1.433 lb	
LB216	mm	50 h6	161	32	24	18	18	48	10.5	20			21.5	2.0 kg	
	in	1.969	6.339	1.26	0.945	0.709	0.709	1.89	0.413	0.787			0.847	4.409 lb	
LB217	mm	65 h6	196	32	26	20	25	65	10.5	22.5			28.5	4.4 kg	
	in	2.559	7.717	1.26	1.024	0.787	0.984	2.559	0.413	0.886			1.122	9.700 lb	
LB218	mm	85 h6	258	34	39	35	28	89	10.5	28	32	35	10.6 kg	Optional lubrication ^{a)}	
	in	3.347	10.158	1.339	1.535	1.378	1.102	3.504	0.413	1.102	1.260	1.378	23.369 lb		
LB220	mm	100 h6	347	36	61	55	35	120	10.5	36	35	45	19.2 kg		
	in	3.937	13.661	1.417	2.402	2.165	1.378	4.724	0.413	1.417	1.378	1.772	42.328 lb		
LB221	mm	120 h6	347	36	61	55	35	120	12.5	40	35	45	28.4 kg		
	in	4.724	13.661	1.417	2.402	2.165	1.378	4.724	0.492	1.575	1.378	1.772	62.611 lb		

a) Oiler $\varnothing 4$ DIN 3405D or M10 DIN 3405A

NOTE: 3D STEP files of most of our products are available on our website: www.magtrol.com ; other files are available on request.

TECHNICAL DATA - LB 23X SERIES

STANDARD VERSION ^{a)}	LB 231	LB 232	LB 233	LB 234	LB 235	LB 236	LB 237	LB 238	LB 240	LB 241
--------------------------------	--------	--------	--------	--------	--------	--------	--------	--------	--------	--------

LOAD MEASUREMENT

Nominal Load (Metric) ^{b)}	5 kN	10 kN	20 kN	50 kN	70 kN	100 kN	200 kN	500 kN	1000 kN	1250 kN
Nominal Load (US) ^{b)}	0.28 tf	1.12 tf	2.25 tf	5.62 tf	7.87 tf	11.24 tf	22.48 tf	56.20 tf	112.4 tf	140.5 tf
Overload Admissible (% of NL)	150 % of rated load without influence on measurement									
Overload at Rupture (of rated load)	≥500 %							400 %	300 %	
Non-linearity Error ^{b)}						<0.25 %				
Non-linearity + Hysteresis Error ^{b)}						<0.4 %				
Repeatability ^{b)}						±0.1 %				

MECHANICAL CHARACTERISTICS & ENVIRONMENT

Operating Principle	Double full-bridge strain gauge									
Material	Stainless steel 1.4057									
Operating Temperature	-25 °C to +80 °C									
Storage Temperature	-55 °C to +125 °C									
Temperature Influence on Zero ^{b)}	±0.02 % / K									
Temperature Influence on Sensitivity	±0.02 % / K									
Fit	G7 / h6									
Angle influence on signal output ^{c)}	According to the cosine function									
Protection Class	IP 67 according to DIN 60529									

SAFETY STANDARDS

OIML Class	Not available			R60 D0.1			Not available		
------------	---------------	--	--	----------	--	--	---------------	--	--

ELECTRICAL CHARACTERISTICS & CONNECTIONS

Bridge Impedance Input	800 Ω									
Bridge Impedance Output	700 Ω									
Power Supply	5 to 12 VDC/AC									
Zero Adjustment ^{b)}	±1 %									
Transducer Sensitivities	0.5 mV/V ±3 %			1 mV/V ±3 %			1.8 mV/V ±3 %			

Output Connector	Axial connector, Souriau 8525 IH 10B06 PNH									
Connection Cable Assembly (option)	3m, 6m, 12m or 20m cable with axial or 90° connector ^{d,e)}									

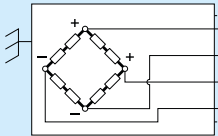
Wiring Colors	 <table border="0" style="margin-left: 20px;"> <tr> <td>Supply +</td> <td>: red</td> </tr> <tr> <td>Supply -</td> <td>: blue</td> </tr> <tr> <td>Signal +</td> <td>: white</td> </tr> <tr> <td>Signal -</td> <td>: green</td> </tr> <tr> <td>Case / Shield</td> <td>: black</td> </tr> </table>										Supply +	: red	Supply -	: blue	Signal +	: white	Signal -	: green	Case / Shield	: black
Supply +	: red																			
Supply -	: blue																			
Signal +	: white																			
Signal -	: green																			
Case / Shield	: black																			

a) Rating apply to standard load pins only, special models available on request.

b) Of full scale.

c) Variation of the measuring signal due to the angle positioning.

d) Axial connector: Souriau 85106JC 10 6S50, 90° connector: Souriau 85108EC 106S50.

e) Other longer cables lengths available on request.

DIMENSIONS LB 23X SERIES

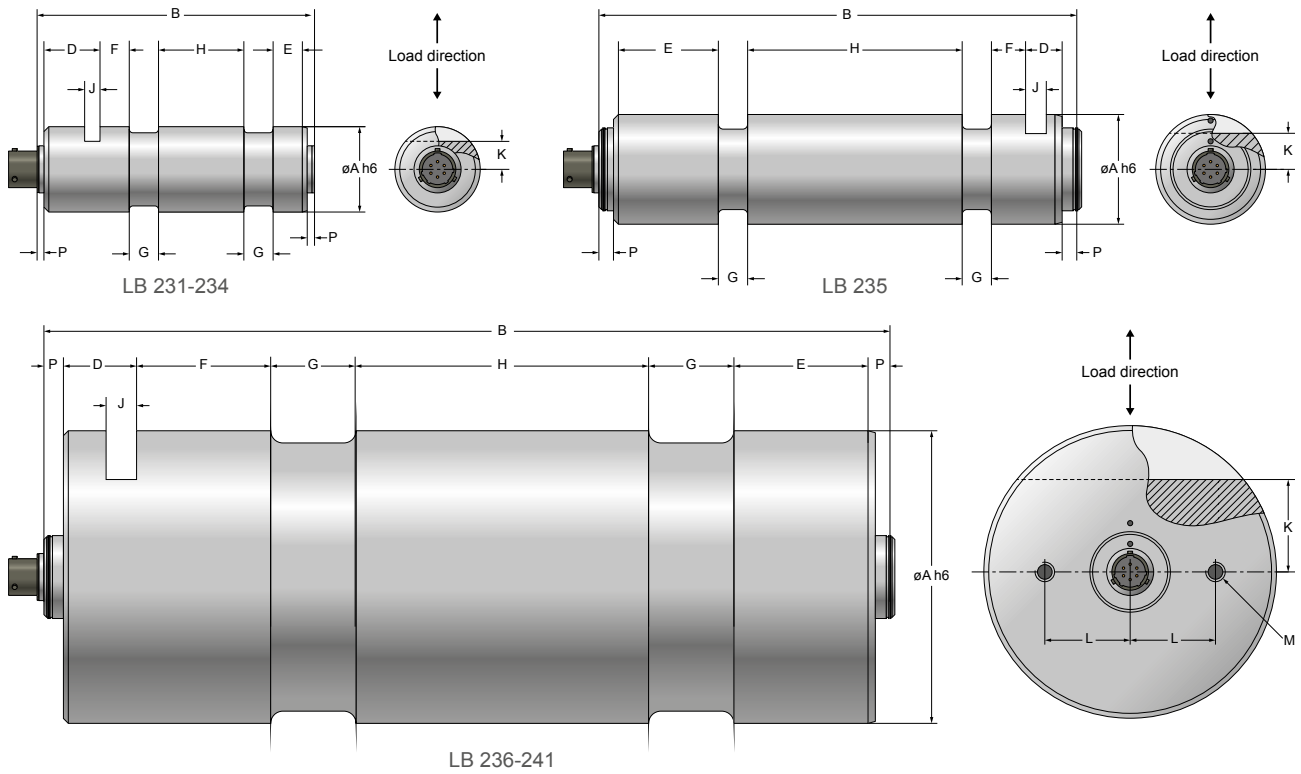

NOTE: Original dimensions are in metric units. Dimensions converted to imperial units have been rounded up to 3 decimal places.

MODEL	UNITS	ØA	B	D	E	F	G	H	J	K	L	M	P	WEIGHT						
LB 231-233	mm	25h6	86	16	14	10	7	24	5.2	9	N/A	N/A	3	0.2 kg						
	in	0.984	3.386	0.630	0.551	0.394	0.276	0.945	0.205	0.354			0.118	0.441 lb						
LB 234	mm	35h6	114	23	12	12	12	35	6.3	11.5			N/A	N/A	3	0.65 kg				
	in	1.378	4.488	0.906	0.472	0.472	0.472	1.378	0.248	0.453					0.118	1.433 lb				
LB 235	mm	45h6	196	15	41	14	12	88	8.5	16					N/A	N/A	6	1.8 kg		
	in	1.772	7.717	0.591	1.614	0.551	0.472	3.465	0.335	0.630							0.236	3.968 lb		
LB 236	mm	50h6	165	28	20	18	18	48	10.5	20							N/A	N/A	6	2 kg
	in	1.969	6.496	1.102	0.787	0.709	0.709	1.890	0.413	0.787									0.236	4.409 lb
LB 237	mm	65h6	200	28	22	20	25	65	10.5	22.5	N/A	N/A							6	4.4 kg
	in	2.559	7.874	1.102	0.866	0.787	0.984	2.559	0.413	0.886									0.236	9.700 lb
LB 238	mm	85h6	262	30	35	35	28	89	10.5	28			25	M6					6	10.6 kg
	in	3.346	10.315	1.181	1.378	1.378	1.102	3.504	0.413	1.102			0.984						0.236	23.369 lb
LB 240	mm	100h6	351	30	55	55	35	120	10.5	36			35	M8	8	19.2 kg				
	in	3.937	13.819	1.181	2.165	2.165	1.378	4.724	0.413	1.417			1.378		0.315	42.329 lb				
LB 241	mm	120h6	351	30	55	55	35	120	12.5	40			35		M8	8	28.4 kg			
	in	4.724	13.819	1.181	2.165	2.165	1.378	4.724	0.492	1.575			1.378			0.315	62.611 lb			

NOTE: 3D STEP files of most of our products are available on our website: www.magtrol.com ; other files are available on request.

ACCESSORIES LB 2XX SERIES

CABLE ASSEMBLIES

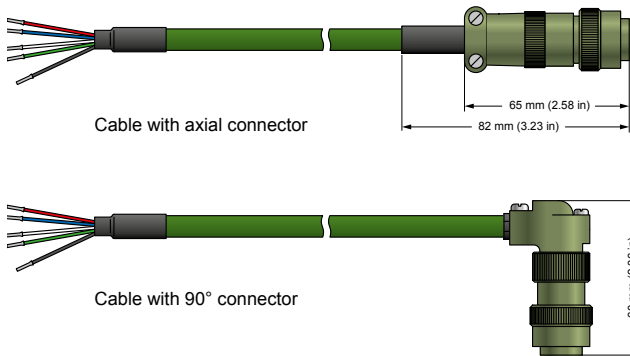

CABLE ASSEMBLY ORDERING INFORMATION

ORDERING NUMBER EH 13 / 0 X

8 : Axial connector
9 : 90° connector

1 : Cable length 3 m
2 : Cable length 6 m
3 : Cable length 12 m
4 : Cable length 20 m^{a)}

a) Other longer cables lengths available on request.

PIN CONFIGURATION

Power Supply +	red	A
Power Supply -	blue	B ^{a)}
Signal +	white	C
Signal -	green	D ^{a)}
Case	black	E

a) Pins B and D are connected together. This feature allows the user to cancel the voltage drop error due to the supply current on the cable (4-wire measurement).

COUNTER CONNECTOR

Axial connector	PN 957-11-08-0030
90° connector	PN 957-11-08-0029

ORDERING INFORMATION LB 21X SERIES

STANDARD MODEL / ORDERING NUMBER LB 2 / 0 0 -

10, 11, ..., 13 : Model LB 21X (Connection: PG Axial)
14, 16, ..., 21 : Model LB 21X (Connection: PG Radial)

OPTIONAL MODEL / ORDERING NUMBER LB 2 / - -

14, 16, ..., 21 : Model LB 21X (Connection: PG Radial)

0 : Without Lubrication (standard)
1 : With Lubrication (available only on LB 216-221)

Electrical Connection:
0 : PG Radial (standard)
1 : PG Axial
2 : Radial Connector

Connection cable:
0 : Connector (axial or radial)
1 : Cable length 3 m
2 : Cable length 6 m
3 : Cable length 12 m
4 : Cable length 20 m^{a)}

a) Other longer cables lengths available on request.

Example: LB218 Load Measuring Pin (Optional Model) with lubrication, PG Axial and 6m cable would be ordered as follows: LB218/112.

LB212 Load Measuring Pin (Standard Model) with 3m cable would be ordered as follows: LB212/001.

ORDERING INFORMATION LB 23X SERIES

ORDERING NUMBER LB 2 / XXX

31, 32, ... 41 : Model LB 23X

Example: LB 237 Load Measuring Pin would be ordered as follows: LB 237/XXX.

SYSTEM OPTIONS & ACCESSORIES

MB-02 SERIES - MINIATURE LOAD PINS



Fig. 4: Miniature Load Pin **MB-02-10-10-2**

Magtrol Load Measuring Pins are used to measure load and force and provide overload protection. The pins are mounted into machines in place of normal shafts and fitted with strain gauges, allowing them to produce a signal proportional to the measured load.

Manufactured in Switzerland, Magtrol's MB-02 Series Miniature Load Pins are rugged with high resistance stainless steel and tight construction, designed specifically for use in harsh industrial environments.

The compact design as well as the high protection class give this sensor an excellent aptitude for the measurement and monitoring of forces and overloads on mechanical compact applications, as well as in harsh environments.

AN SERIES - LOAD MONITOR DISPLAY WITH INTEGRATED SIGNAL CONDITIONER



Fig. 5: **AN 1500 M** - Load Monitor Display with integrated signal conditioner

The AN 1500 M Load Monitor is designed to process and display signals coming from various types of transducers (weight, load, pressure, torque, etc.) that use standard strain-gauge bridges.

The basic instrument is a soldered assembly composed of a main board, a tri-color programmable display and a power circuit. Standard features include the reading of the input variable as well as remote hold, reading and memorization of max and min values (peak / valley), tare and reset function.

LMU SERIES - LOAD MONITORING UNIT



Fig. 6: **LMU 216** - Load Monitoring Unit

Magtrol's Load Monitoring Units are used for measuring load, force and weight from signals generated by strain gauge transducers. Specifically designed for use with Magtrol's Load Measuring Pins and Load-Force-Weight Sensors, the LMU Series provides excitation voltage while conditioning the bridge output signal.

Each unit contains DIP-switches and jumpers for greater flexibility and complete adaptability. User-defined alarm limits can be configured into the unit, which when combined with our sensors, provides a safe and rugged measurement system that continuously monitors for short-circuits and interrupted signal lines. Magtrol LMUs are specially designed for use in harsh environments and are suitable for crane security systems.

GAD SERIES - LARGE DIGITAL DISPLAYS



Fig. 7: **GAD 6** - digits height 102mm - Large Digital Display

These high quality, large character digital displays can be used for crane weight display, process weight display, and all other remote weighing applications. They use microprocessor based technology for high reliability and have a non-volatile memory to store all the calibration data.

Magtrol Large Digital Displays are used with Load Monitoring Units (LMUs) or signal conditioners (AN Series), as part of a complete measurement system. Magtrol load measuring pins, which measure load and force to provide overload protection, are available for a wide range of Load-Force-Weight, and in various executions and accuracy classes. Combined, these products constitute an ideal safe measurement system for continuous overload monitoring.

1.3.2 LE SERIES - LOAD MEASURING PINS

LE SERIES

LOAD MEASURING PINS

MAGTROL offers a wide range of Load-Force-Weight Transducers with optional integrated electronics or Load Monitoring Units (LMU) with B.I.T.E. functions creating an ideal measurement system which continuously checks for overloads and short circuits. Ideally for use on Safety Applications according to **ECE-R10, ISO 13849-1 : CAT4 & PLe** and **IEC 62061 : SIL3** (LE 6XX SERIES); **ISO 13849-1 : CAT2 & PLd** and **IEC 62061 : SIL2** (LE 4XX SERIES).

FEATURES

- Temperature-compensated transducers with strain gauges in full-bridge configuration. On request, available with double bridge redundant.
- Available in several standard ranges from 2.5kN to 1250 kN (0.28 tf to 140.5 tf).
- Electronics for transmission over great distances:
 - 2 wires (LE 2XX) 4-20 mA
 - 3 wires (LE 4XX) 4-20 mA
 - 6 wires (LE 6XX) available with dual channels 4-20 mA
- Built-in test equipment (B.I.T.E.) included on LE 4XX Series & LE 6XX Series.
- Complies with Safety Standards ISO 13849-1 and IEC 62061.
- EMC execution for reliable trouble-free operation.
- Rugged design corresponding to the quality characteristics of LB 2XX series.
- Insensitive to external mechanical and chemical effects.
- Ideal for use in hostile environments.
- Simple installation for cost-saving solutions to construction problems.
- Calibrated Output: 4-20 mA.

DESCRIPTION

Magtrol Load Measuring Pins are used to measure load and force, and provide overload protection. The pins are mounted into machines in place of normal shafts and fitted with strain gauges, allowing them to produce a signal proportional to the measured load. Manufactured in Switzerland, Magtrol's LE Series Load Measuring Pins are rugged with high resistance stainless steel and tight construction. Available in several standard ranges from 2.5 kN to 1250 kN, their operation remains trouble-free and reliable even in electromagnetically difficult environmental conditions.



Fig. 1: Load Measuring Pin model LE 621, LE 418 (back); LE 217 & LE 211 (front)

APPLICATIONS

When forces acting on mechanical constructions are measured, the additional equipment required can often be costly and difficult to install. Magtrol Load Measuring Pins offer an excellent solution since they act as a direct element in the assembly, replacing a non-instrumented pin or shaft. LE Series Load Measuring Pins are used for measuring loads and overload protection on cranes, hoisting gear, elevators and winches. The integrated electronics makes them ideal for applications in which separate signal conditioning is difficult to install and where the monitoring electronics are positioned at extended distances.

DESIGN

Magtrol's Load Measuring Pins have two circular grooves and an axial bore. Inside the central bore, adjacent to the external grooves, the strain gauges are mounted in a full-bridge configuration. The positioning and orientation of the strain gauges have been optimized by means of the finite element method (FEM).

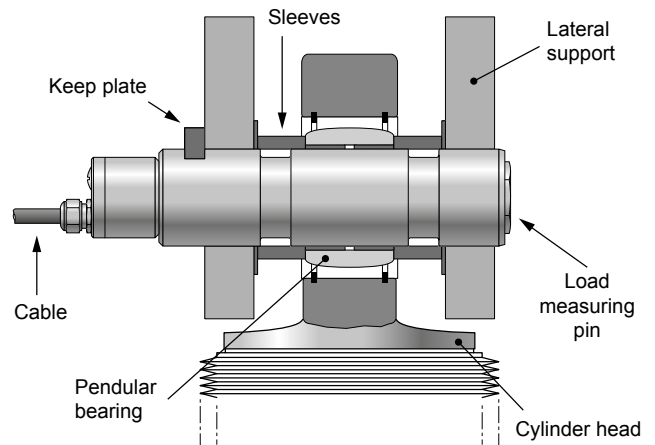

Fig.2: Mounting example

OPERATING PRINCIPLE

When force is applied to the Load Measuring Pin along its sensitive axis, the effect on the strain gauge bridge results in an output signal proportional to the applied force. The signal is then converted by the integrated electronics to a standard 4 to 20mA output. Based on SMD (Surface Mounted Device) technology, the electronics are well-protected against conducted and radiated electromagnetic fields.

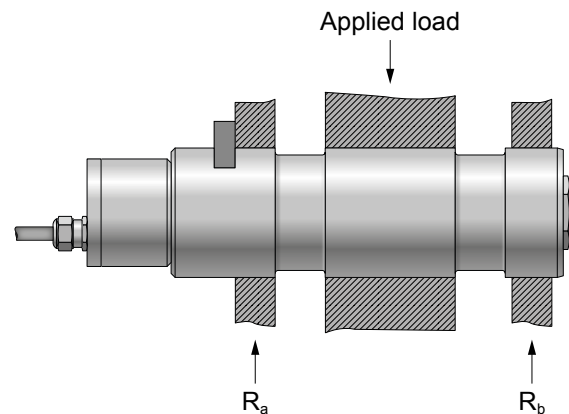
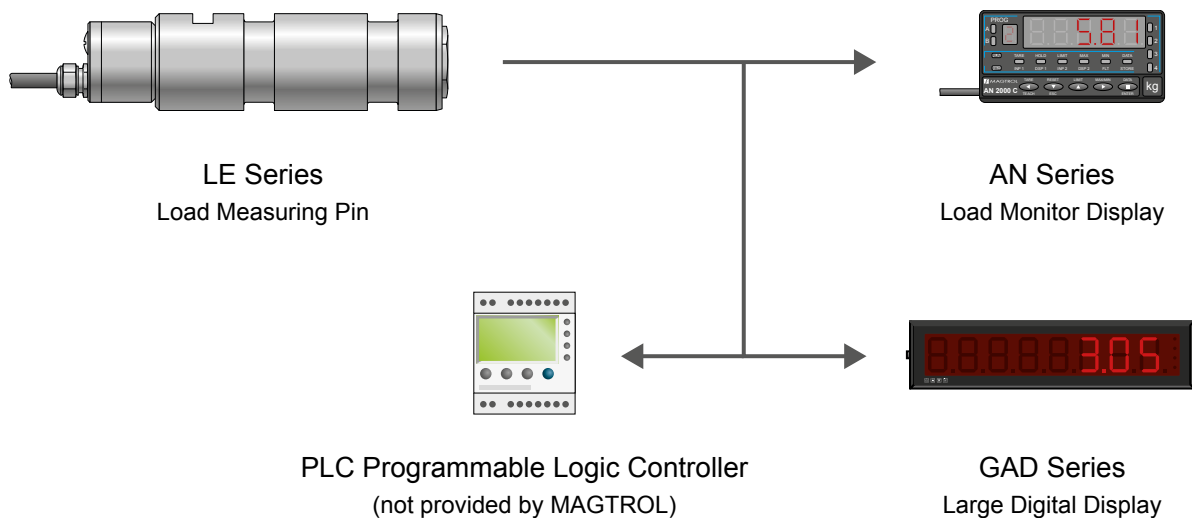

Fig.3: R_a should equal R_b so that the force is evenly distributed

SYSTEM CONFIGURATION



TECHNICAL DATA - LE 4XX SERIES

STANDARD VERSION 1 CHANNEL ^{a)}	LE 410	LE 411	LE 412	LE 413	LE 414	LE 416	LE 417	LE 418	LE 420	LE 421
---	--------	--------	--------	--------	--------	--------	--------	--------	--------	--------

LOAD MEASURING

Nominal Load (Metric) ^{b)}	2.5 kN	5 kN	10 kN	20 kN	50 kN	100 kN	200 kN	500 kN	1 000 kN	1 250 kN
Nominal Load (US) ^{b)}	0.28 tf	0.56 tf	1.12 tf	2.25 tf	5.62 tf	11.24 tf	22.48 tf	56.2 tf	112.4 tf	140.5 tf
Overload Admissible (% of NL)	150 % (of rated load without influence on measurement)									
Overload at Rupture (% of NL)	≥ 500 %							400 %	300 %	
Non-linearity Error ^{b)}	< 0.25 %								< 0.5 %	
Non-linearity + Hysteresis Error ^{b)}	< 0.5 %								< 0.8 %	
Repeatability ^{b)}	± 0.1 %									
Standard Calibration	4 mA - 20 mA corresponds to 0 kN - Full Scale Deflection in kN									

MECHANICAL CHARACTERISTICS & ENVIRONMENT

Technology	Full-bridge strain gauge									
Material	Stainless steel 1.4057									
Lubrication	Not available					Oiler ø4 DIN 3405D or M10 DIN 3405A				
Operating Temperature	-25 °C to +80 °C									
Storage Temperature	-30 °C to +90 °C									
Temperature Influence on Zero ^{b)}	± 0.02 % / K									
Temperature Influence on Sensitivity	± 0.02 % / K									
Long Term Stability of Zero ^{b)}	< 1 % / year (not cumulative)									
Long Term Stability of Sensitivity	< 0.5 % / year (not cumulative)									
EMC Vehicle approval (E)	According to EN61326-1, EN61326-2-3 ECE-R10									
Angle influence on signal output ^{c)}	According to the cosine function									
Protection Class	IP66 (connected) ^{e)} according to EN 60529									

SAFETY STANDARDS & B.I.T.E.

Safety Standards	ISO 13849-1 : CAT2 and PLd IEC 62061 : SIL 2									
Type of B.I.T.E. input	Active low, compatible with switch, relay, open collector or open drain, 1 B.I.T.E									
Effect on the output	Addition of 70 % (± 10 %) of the nominal load in standard (other % in option)									

ELECTRICAL CHARACTERISTICS & CONNECTIONS

Strain Gauge Bridge Impedance	350 Ω									
Power Supply	19 to 32VDC (with protected polarity reversal)									
Output Signal	Rated 4 to 20 mA; max. 0.5 to 22 mA									
Load Resistance	Admissible resistance of 3-wire circuit at connection of LE 4XX series					<p>Hatched: Operating Domain = $\frac{\text{Load Resistance } R_L}{\text{Supply Voltage } U_s}$</p>				
Output	Integrated 3m, 6m, 12m or 20m, cable Radox K-414 (standard) ^{d)} or axial connector HUMMEL M16									
Configuration	3-wires									
Optional Connection Cable Assembly	3m, 6m, 12m or 20m cable with connector HUMMEL M16 female ^{d)}									
Wiring Colors	<ul style="list-style-type: none"> Power Supply + : red Ground (GND) - : blue Current Output + : white B.I.T.E : green Case / Shield : yellow / black 									

a) Rating apply to standard load pins only, special models available on request.

b) Full scale.

c) Variation of the measuring signal due to the angle positioning.

d) Other longer cables lengths available on request.

e) When the counter-connector is connected

TECHNICAL DATA - LE 6XX SERIES

STANDARD VERSION 2 CHANNELS ^{a)}	LE 610	LE 611	LE 612	LE 613	LE 614	LE 616	LE 617	LE 618	LE 620	LE 621
--	--------	--------	--------	--------	--------	--------	--------	--------	--------	--------

LOAD MEASURING

Nominal Load (NL) (Metric) ^{b)}	2.5 kN	5 kN	10 kN	20 kN	50 kN	100 kN	200 kN	500 kN	1 000 kN	1 250 kN
Nominal Load (NL) (US) ^{b)}	0.28 tf	0.56 tf	1.12 tf	2.25 tf	5.62 tf	11.24 tf	22.48 tf	56.2 tf	112.4 tf	140.5 tf
Overload Admissible (% of NL)	150 % (of rated load without influence on measurement)									
Overload at Rupture (% of NL))	≥500 %							400 %	300 %	
Non-linearity Error ^{b)}	<0.25 %							<0.5 %		
Non-linearity + Hysteresis Error ^{b)}	<0.5 %							<0.8 %		
Repeatability ^{b)}	±0.1 %							±0.1 %		
Standard Calibration	4 mA - 20 mA corresponds to 0 kN - Full Scale Deflection in kN									

MECHANICAL CHARACTERISTICS & ENVIRONMENT

Technology	2x Full-bridge strain gauge									
Material	Stainless steel 1.4057									
Lubrication	Not available					Oiler ø4 DIN 3405D or M10 DIN 3405A				
Operating Temperature	-25 °C to +80 °C									
Storage Temperature	-30 °C to +90 °C									
Temperature Influence on Zero ^{b)}	±0.02 % / K									
Temperature Influence on Sensitivity	±0.02 % / K									
Long Term Stability of Zero ^{b)}	<1 % / year (not cumulative)									
Long Term Stability of Sensitivity	<0.5 % / year (not cumulative)									
EMC Vehicle approval (E)	According to EN61326-1, EN61326-2-3 ECE-R10									
Angle influence on signal output ^{c)}	According to the cosine function									
Protection Class	IP66 (connected) ^{e)} according to EN60529									

SAFETY STANDARDS & DUAL B.I.T.E.

Safety Standards	ISO 13849-1 : CAT4 and PLe IEC 62061 : SIL 3									
Type of B.I.T.E. input.	Active low, compatible with switch, relay, open collector or open drain, 1 B.I.T.E. input for each channel									
Effect on the output	Addition of 70 % (± 10 %) of the nominal load in standard (other % in option)									

ELECTRICAL CHARACTERISTICS & CONNECTIONS

Strain Gauge Bridge Impedance	2 x 350 Ω									
Power Supply	19 to 32VDC (with protected polarity reversal (1x or 2x))									
Output Signal 2 channels	Rated 4 to 20 mA; max. 0.5 to 22mA (2x)									
Output	Integrated 3m, 6m, 12m or 20m cable Radox K-814 (standard) ^{d)} or axial connector HUMMEL M16									
Configuration	6-wire									
Optional Connection Cable Assembly	3m, 6m, 12m or 20m cable with connector HUMMEL M16 female ^{d)}									

Load Resistance

Admissible resistance of 6-wire circuit at connection of LE 6XX series

Hatched:
Operating Domain = $\frac{\text{Load Resistance } R_L}{\text{Supply Voltage } U_a}$

Wiring Colors

- Power Supply + : red
- Ground (GND) - : blue
- Current Output + : withe
- B.I.T.E : green
- Power Supply + : brown
- Ground (GND) - : black
- Current Output + : grey
- B.I.T.E : yellow
- Case / Shield : yellow / black

a) Rating apply to standard load pins only, special models available on request.

b) Full scale.

c) Variation of the measuring signal due to the angle positioning.

d) Other longer cables lenghts available on request.

e) When the counter-connector is connected

DIMENSIONS LE 4XX-6XX SERIES

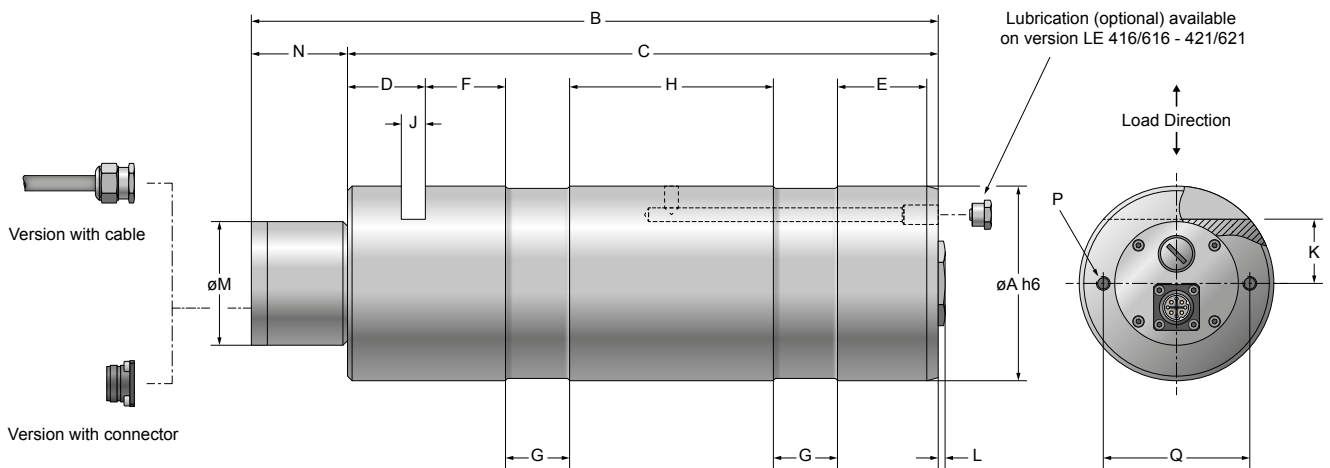

NOTE: Original dimensions are in Metric units. Dimensions converted to English units have been rounded up to 3 decimal places.

MODEL	units	øA	B	C	D	E	F	G	H	J	K	L	øM	N	WEIGHT
LE410/610	mm	25 h6	137	84	18	16	10	7	24	5.2	9	3	54	57	0.6 kg
	in	0.984	5.394	3.307	0.709	0.63	0.394	0.276	0.945	0.205	0.354	0.118	2.126	2.244	1.323 lb
LE411/611	mm	25 h6	137	84	18	16	10	7	24	5.2	9	3	54	57	0.6 kg
	in	0.984	5.394	3.307	0.709	0.63	0.394	0.276	0.945	0.205	0.354	0.118	2.126	2.086	1.323 lb
LE412/612	mm	25 h6	137	84	18	16	10	7	24	5.2	9	3	54	57	0.6 kg
	in	0.984	5.394	3.307	0.709	0.63	0.394	0.276	0.945	0.205	0.354	0.118	2.126	2.086	1.323 lb
LE 413/613	mm	25 h6	137	84	18	16	10	7	24	5.2	9	3	54	57	0.6 kg
	in	0.984	5.394	3.307	0.709	0.63	0.394	0.276	0.945	0.205	0.354	0.118	2.126	2.086	1.323 lb
LE414/614	mm	35 h6	165	112	25	14	12	12	35	6.3	11.5	3	54	42	1.05 kg
	in	1.378	6.496	4.409	0.984	0.551	0.472	0.472	1.378	0.248	0.453	0.118	2.126	1.654	2.315 lb
LE416/616	mm	50 h6	214	161	32	24	18	18	48	10.5	20	3	54	42	2.4 kg
	in	1.969	8.425	6.339	1.26	0.945	0.709	0.709	1.89	0.413	0.787	0.118	2.126	1.654	5.291 lb
LE417/617	mm	65 h6	249	196	32	26	20	25	65	10.5	22.5	3	54	42	4.8 kg
	in	2.559	9.803	7.717	1.26	1.024	0.787	0.984	2.559	0.413	0.886	0.118	2.126	1.654	10.582 lb
LE418/618	mm	85 h6	311	258	34	39	35	28	89	10.5	28	3	54	42	11 kg
	in	3.347	12.244	10.158	1.339	1.535	1.378	1.102	3.504	0.413	1.102	0.118	2.126	1.654	24.251 lb
LE420/620	mm	100 h6	400	347	36	61	55	35	120	10.5	36	3	54	42	19.6 kg
	in	3.937	15.748	13.661	1.417	2.402	2.165	1.378	4.724	0.413	1.417	0.118	2.126	1.654	43.211 lb
LE421/621	mm	120 h6	400	347	36	61	55	35	120	12.5	40	3	54	42	28.8 kg
	in	4.724	15.748	13.661	1.417	2.402	2.165	1.378	4.724	0.492	1.575	0.118	2.126	1.654	63.493 lb

MODEL	units	P	Q	LUBRICATION
LE410-414/610-614				N/A
LE416/616	N/A	N/A	N/A	Optional lubrication ^{a)}
LE417/617				
LE418/618	mm	M6	64	
	in		2.520	
LE420/620	mm	M8	70	
	in		2.756	
LE421/621	mm		70	
	in		2.756	

a) Oiler ø4 DIN 3405 D or M10 DIN 3405 A

NOTE: 3D STEP files of most of our products are available on our website: www.magtrol.com ; other files are available on request.

TECHNICAL DATA - LE 2XX SERIES

STANDARD VERSION ^{a)}	LE211	LE212	LE213	LE214	LE216	LE217	LE218	LE220	LE221
LOAD MEASURING									
Nominal Load (NL) (Metric) ^{b)}	5 kN	10 kN	20 kN	50 kN	100 kN	200 kN	500 kN	1 000 kN	1 250 kN
Nominal Load (NL) (US) ^{b)}	0.56 tf	1.12 tf	2.25 tf	5.62 tf	11.24 tf	22.48 tf	56.2 tf	112.4 tf	140.5 tf
Overload Admissible (% of NL)	150 % (without influence on measurement)								
Overload at Rupture (% of NL)	> 500 %						400 %	300 %	
Non-linearity Error ^{b)}	< 0.25 %							< 0.5 %	
Non-linearity + Hysteresis Error ^{b)}	< 0.5 %							< 0.8 %	
Repeatability ^{b)}	± 0.1 %								
Standard Calibration	4 mA - 20 mA corresponds to 0 kN - Full Scale Deflection in kN								
MECHANICAL CHARACTERISTICS									
Technology	Full-bridge strain gauge								
Material	Stainless steel 1.4057								
Lubrication	Not available				Oiler ø4 DIN 3405 D or M10 DIN 3405 A				
ENVIRONMENT									
Operating Temperature	-25 °C to +80 °C								
Storage Temperature	-30 °C to +90 °C								
Temperature Influence on Zero ^{b)}	± 0.02 % / K								
Temperature Influence on Sensitivity	± 0.02 % / K								
Long Term Stability on Zero ^{b)}	< 1 % / year (not cumulative)								
Long Term Stability on Sensitivity	< 0.5 % / year (not cumulative)								
EMC	According to EN61000-6-2 & EN61326-1								
Influence α on Measurement Signal ^{c)}	According to the cosine function								
Protection Class	IP 66 according to DIN 60529								
ELECTRICAL CHARACTERISTICS & CONNECTIONS									
Strain Gauge Bridge Impedance:	5 000 Ω								
Power Supply	12 to 32 VDC (with protected polarity reversal < 35 mA)								
Output Signal	Rated 4 to 20 mA; max. 3.5 to 25 mA								
Load Resistance	Admissible resistance of the 2-wire circuit at the connection of the LE 2XX								
	$\text{Hatched: Operating Domain} = \frac{\text{Load Resistance } R_L}{\text{Supply Voltage } U_a}$								
Output Connector	Axial connector, Souriau 85102 E 106P50								
Configuration	2-wire								
Optional Connection Cable Assembly	3 m, 6 m, 12 m or 20 m cable with axial or 90° connector ^{d,e)}								

a) Ratings apply to standard load pins only, special models are available by contacting Magtrol.

b) Full scale.

c) Variation of the measuring signal due to the angle positioning.

d) Axial connector: Souriau 85106 JC 10 6S50, 90° connector: Souriau 85108 EC 106S50.

e) Other longer cables lengths available on request.

DIMENSIONS LE 2XX SERIES

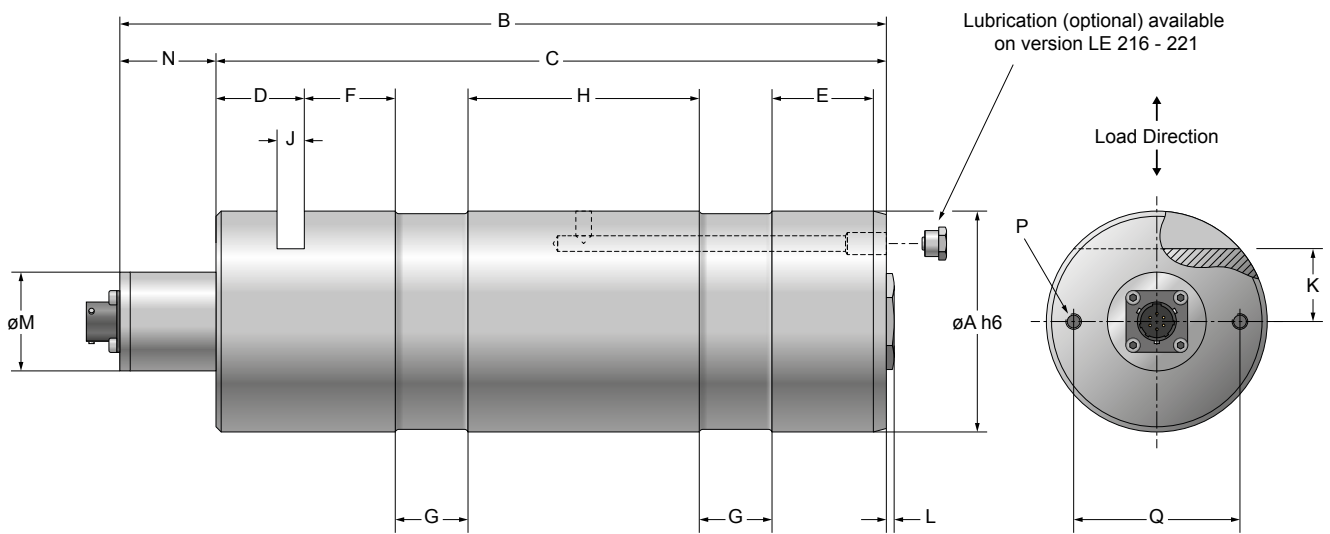

NOTE: Original dimensions are in Metric units. Dimensions converted to English units have been rounded up to 3 decimal places.

MODEL	units	øA	B	C	D	E	F	G	H	J	K	L	øM	N	Weight
LE211	mm	25 h6	136	84	18	16	10	7	24	5.2	9	3	38	52	0.6 kg
	in	0.984	5.354	3.307	0.709	0.63	0.394	0.276	0.945	0.205	0.354	0.118	1.496	2.047	1.323 lb
LE212	mm	25 h6	136	84	18	16	10	7	24	5.2	9	3	38	52	0.6 kg
	in	0.984	5.354	3.307	0.709	0.63	0.394	0.276	0.945	0.205	0.354	0.118	1.496	2.047	1.323 lb
LE213	mm	25 h6	136	84	18	16	10	7	24	5.2	9	3	38	52	0.6 kg
	in	0.984	5.354	3.307	0.709	0.63	0.394	0.276	0.945	0.205	0.354	0.118	1.496	2.047	1.323 lb
LE214	mm	35 h6	149	112	25	14	12	12	35	6.3	11.5	3	38	37	1.05 kg
	in	1.378	5.866	4.409	0.984	0.551	0.472	0.472	1.378	0.248	0.453	0.118	1.496	1.457	2.315 lb
LE216	mm	50 h6	198	161	32	24	18	18	48	10.5	20	3	38	37	2.4 kg
	in	1.969	7.795	6.339	1.26	0.945	0.709	0.709	1.89	0.413	0.787	0.118	1.496	1.457	5.291 lb
LE217	mm	65 h6	233	196	32	26	20	25	65	10.5	22.5	3	38	37	4.8 kg
	in	2.559	9.173	7.717	1.26	1.024	0.787	0.984	2.559	0.413	0.886	0.118	1.496	1.457	10.582 lb
LE218	mm	85 h6	295	258	34	39	35	28	89	10.5	28	3	38	37	11 kg
	in	3.347	11.614	10.158	1.339	1.535	1.378	1.102	3.504	0.413	1.102	0.118	1.496	1.457	24.251 lb
LE220	mm	100 h6	384	347	36	61	55	35	120	10.5	36	3	38	37	19.6 kg
	in	3.937	15.118	13.661	1.417	2.402	2.165	1.378	4.724	0.413	1.417	0.118	1.496	1.457	43.211 lb
LE221	mm	120 h6	384	347	36	61	55	35	120	12.5	40	3	38	37	28.8 kg
	in	4.724	15.118	13.661	1.417	2.402	2.165	1.378	4.724	0.492	1.575	0.118	1.496	1.457	63.493 lb

MODEL	units	P	Q	LUBRICATION
LE211-214				N/A
LE216	N/A	N/A	N/A	Optional lubrication ^{a)}
LE217				
LE218	mm	M6	64	
	in		2.520	
LE220	mm	M8	70	
	in		2.756	
LE221	mm		70	
	in		2.756	

a) Oiler ø4 DIN 3405D or M10 DIN 3405A

NOTE: 3D STEP files of most of our products are available on our website: www.magtrol.com ; other files are available on request.

ORDERING INFORMATION LE 4XX SERIES

ORDERING NUMBER	LE 4	--	/	--	-	X
	10, 11, 12, ... , 21 : Model LE					
	0 : Without Lubrication (standard) 1 : With Lubrication (available only on LE 416-421)					
	0 : Axial connector 1 : Cable length 3 m 2 : Cable length 6 m 3 : Cable length 12 m 4 : Cable length 20 m ^{a)}					

a) Other longer cables lengths available on request.

Example: LE 416 Load Measuring Pin with lubrication and 6 m cable would be ordered as follows: LE 416/12X.

ACCESSORIES LE 4XX SERIES

CABLE ASSEMBLIES

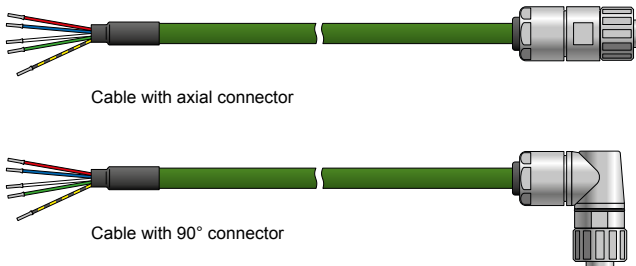

CABLE ASSEMBLY ORDERING INFORMATION

ORDERING NUMBER	EH 14	-	/ 0	-	X
	8 : Axial connector 9 : 90° connector				
	1 : Cable length 3 m 2 : Cable length 6 m 3 : Cable length 12 m 4 : Cable length 20 m ^{a)}				

a) Other longer cables lengths available on request.

LE 4XX PIN CONFIGURATION

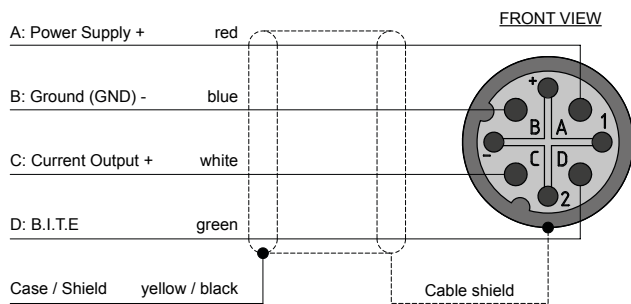

COUNTER CONNECTOR

Axial connector	PN 957-11-07-3101
90° connector	PN 957-11-07-3102

ORDERING INFORMATION LE 6XX SERIES

ORDERING NUMBER	LE 6	--	/	--	--	X
	10, 11, 12, ... , 21					
	0					
	1					
	0					
	1					
	2					
	3					
	4					

10, 11, 12, ... , 21 : Model LE

0 : Without Lubrication (standard)

1 : With Lubrication (available only on LE 616-621)

0 : Axial connector

1 : Cable length 3 m

2 : Cable length 6 m

3 : Cable length 12 m

4 : Cable length 20 m^{a)}

a) Other longer cables lengths available on request.

Example: LE616 Load Measuring Pin with lubrication and 6 m cable would be ordered as follows : LE616/12X.

ACCESSORIES LE 6XX SERIES

CABLE ASSEMBLIES

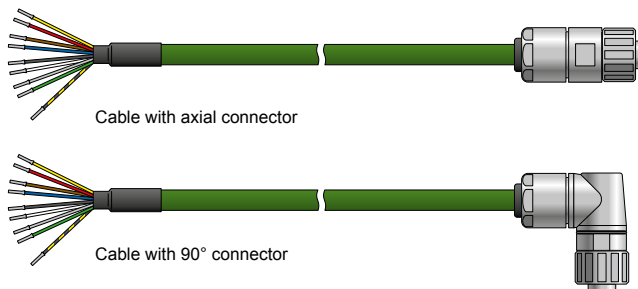

CABLE ASSEMBLY ORDERING INFORMATION

ORDERING NUMBER	ER 11	-	/ 0	-	X
	8				
	9				
	1				
	2				
	3				
	4				

8 : Axial connector

9 : 90° connector

1 : Cable length 3 m

2 : Cable length 6 m

3 : Cable length 12 m

4 : Cable length 20 m^{a)}

a) Other longer cables lengths available on request.

LE 6XX PIN CONFIGURATION (DUAL CHANNELS)

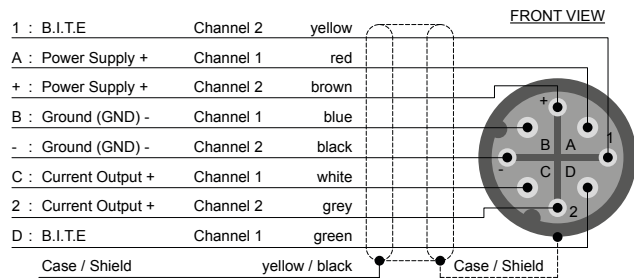

COUNTER CONNECTOR

Axial connector	PN 957-11-07-3111
90° connector	PN 957-11-07-3112

ORDERING INFORMATION LE 2XX SERIES

ORDERING NUMBER LE 2 -- / 0 - X

11, 12, ..., 21 : Model LE

- 1 : Without Lubrication (standard)
- 3 : With Lubrication (available only on LE216-221)

Example: LE 216 Load Measuring Pin with lubrication would be ordered as follows: LE216/03X.

ACCESSORIES LE 2XX SERIES

CABLE ASSEMBLIES

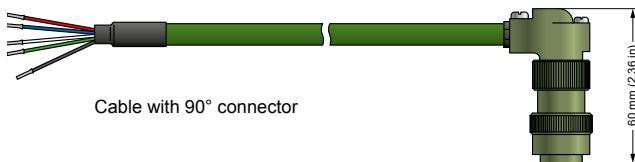
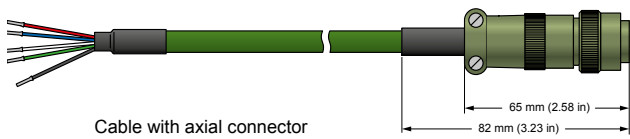

CABLE ASSEMBLY ORDERING INFORMATION

ORDERING NUMBER EH 13 - / 0 - X

- 8 : Axial connector
- 9 : 90° connector

- 1 : Cable length 3 m
- 2 : Cable length 6 m
- 3 : Cable length 12 m
- 4 : Cable length 20 m^{a)}

a) Other longer cables lengths available on request.

LE2XX PIN CONFIGURATION

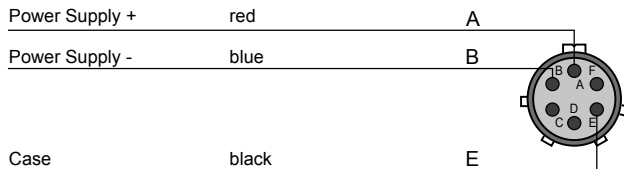

COUNTER CONNECTOR

Axial connector	PN 957-11-08-0030
90° connector	PN 957-11-08-0029

2. INSTALLATION / CONFIGURATION

In order to set up a functional system, it is important to follow the mechanical and electrical procedures described in the following sections. Proper installation is necessary to insure the measured signals will not be disrupted by incorrect mounting.



NOTICE

The procedures contained in this instruction manual do not cover all the existing mounting and connection possibilities. However, they help the user find the appropriate solution for their specific application.

Likewise, installation and connection of load pins specially designed for the specific requirements of the user should be carried out as described in this manual.

Furthermore, the general manufacturer's instructions as well as security standards and recommendations should be respected by the user for special models.

2.1 MOUNTING THE LOAD MEASURING PINS

2.1.1 GENERAL MOUNTING INSTRUCTIONS

Bore the lateral supports and linking element in which the load measuring pin will be placed according to the dimensions and tolerances given in the table below.

TYPE OF LOAD MEASURING PIN	NOMINAL LOAD	NOMINAL DIAMETER	PIN TOLERANCE h6	BORE TOLERANCE G7
	kN	mm	µm	µm
LB 210, LE 410 & LE 610	2.5	25	0 / -13	+28 / +7
LB/LE 211, LB 231, LE 411 & LE 611	5			
LB/LE 212, LB 232, LE 412 & LE 612	10			
LB/LE 213, LB 233, LE 413 & LE 613	20			
LB/LE 214, LB 234, LE 414 & LE 614	50	35	0 / -16	+34 / +9
LB 235	70	45		
LB/LE 216, LB 236, LE 416 & LE 616	100	50	0 / -19	+40 / +10
LB/LE 217, LB 237, LE 417 & LE 617	200	65		
LB/LE 218, LB 238, LE 418 & LE 618	500	85	0 / -22	+47 / +12
LB/LE 220, LB 240, LE 420 & LE 620	1000	100		
LB/LE 221, LB 241, LE 421 & LE 621	1250	120		

NOTE : Machining dimensions and tolerances according to DIN 7161



NOTICE

When bushings are used for adaptation to the load measuring pins, tolerances G7 - N7 (depending on the application type) should be applied.

- Ensure a rigid mounting. The lateral supports should not move with respect to each other when load is applied (see Fig.2-1). Elastic mounting, entailing parasitic forces on the load measuring pin, should be avoided by all means.
- The play between the lateral supports and the linking element (see Fig.2-1) should be limited to values between 0.5 mm and 1 mm. If these parts are pressed against each other, the induced strong lateral contact pressure produces too strong a friction on the gliding surface, thus impeding optimal force transmission to the load measuring pin.
- Use slide (see Fig.2-1) or roller bearings.
- If the load measuring pin is subject to lateral forces, use thrust bearings and spacing or gliding washers between the lateral supports and the linking element to eliminate friction.
- To improve the linearity and hysteresis of the measurement, place antifriction elements into the bores of the lateral supports and linking element.
- The bores in the lateral supports must be cylindrical and concentric to each another. The tolerances indicated in the above figure leave sufficient play for the load measuring pin to slide in place without effort (light-push fit).
- On welded constructions the bores of the lateral supports must be remachined after the welding.

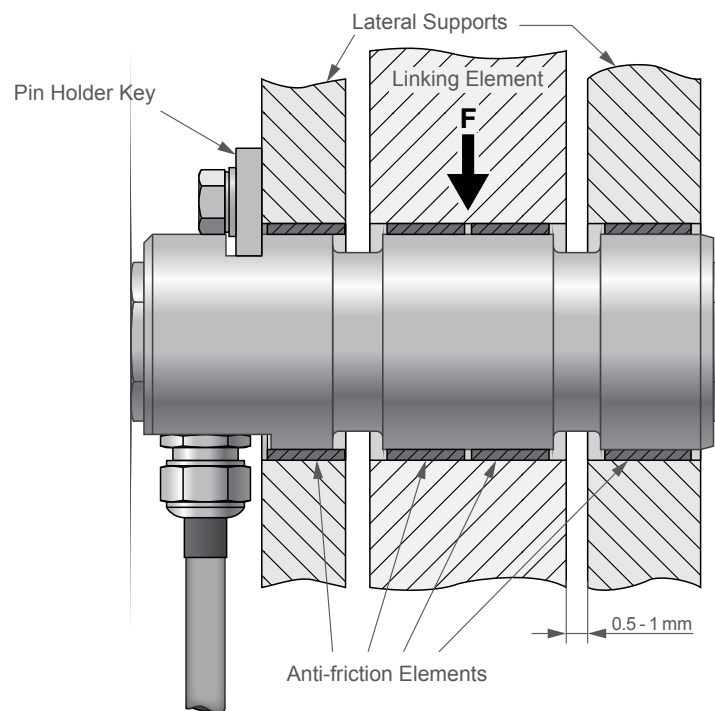

Fig.2-1 Load measuring pin mounted in its seat

2.1.2 PIN HOLDER KEY

8. Machine the pin holder key to the dimensions given (see Fig.2-2). Bore and thread the fastening screw holes according to the specified dimensions (respect both bore and thread depth). The mortise on the load measuring pin is by 0.5 mm wider than the pin holder key. Thus no strain can be transmitted through the key to the pin itself.
9. Prepare 2 screws and 2 single-coil spring-lock washers for the fixing of the pin holder key following the information (see Fig.2-3).

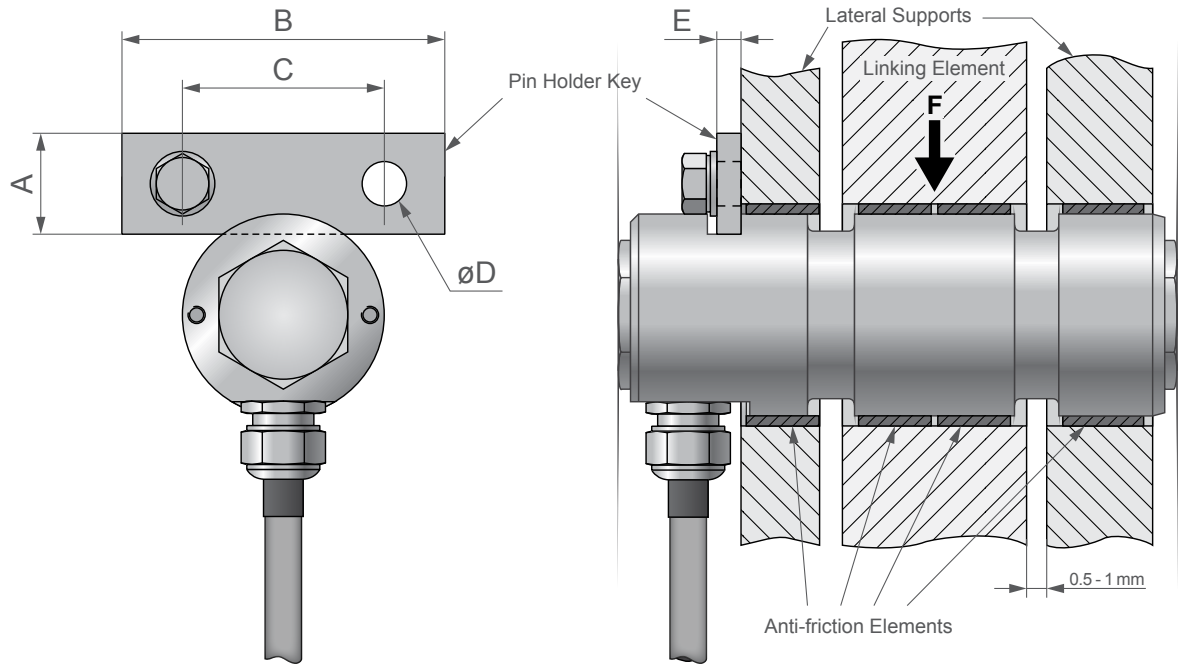

Fig.2-2 Instalation of the pin holder key

TYPE OF LOAD MEASURING PIN	DIMENSIONS mm					FASTENING SCREW	SCREWING TORQUE N·m
	A	B	C	D	E		
LB 210, LE 410 & LE610	20	60	36	9	5	M8	24
LB/LE 211, LB 231, LE 411 & LE 611	20	60	36	9	5	M8	24
LB/LE212, LB 232, LE 412 & LE 612	20	60	36	9	5	M8	24
LB/LE 213, LB 233, LE 413 & LE 613	20	60	36	9	5	M8	24
LB/LE 214, LB 234, LE 414 & LE 614	25	80	50	11	6	M10	48
LB 235	30	100	70	13	8	M12	83
LB/LE 216, LB 236, LE 416 & LE 616	30	100	70	13	8	M12	83
LB/LE 217, LB 237, LE 417 & LE 617	40	140	100	17	10	M16	200
LB/LE 218, LB 238, LE 418 & LE 618	40	140	100	17	10	M16	200
LB/LE 220, LB 240, LE 420 & LE 620	40	140	100	17	10	M16	200
LB/LE 221, LB 241, LE 421 & LE 621	50	190	140	21	12	M20	390

Fig.2-3 Dimensions table for mounting with pin holder key

2.1.3 POSITIONING OF THE LOAD MEASURING PIN



CAUTION

NEVER HIT THE LOAD MEASURING PIN WITH A HAMMER OR ANY OTHER TOOL TO INSERT IT IN ITS SEAT.

MECHANICAL DAMAGE WHICH COULD RESULT IN MEASUREMENT ERRORS MAY OCCUR IF THIS WARNING IS NOT COMPLIED WITH.

ANY BREACH OF THIS WARNING WILL INVALIDATE THE GUARANTEE.

1. Clean the load measuring pin as well as the bores in which it will be placed to ensure clean contact surfaces.
2. Lubricate the load measuring pin as well as the bores in which it will be placed by means of grease or oil.



NOTICE

When mounting roller bearings heat them to about 80 oC to slide them more easily on the load measuring pin.

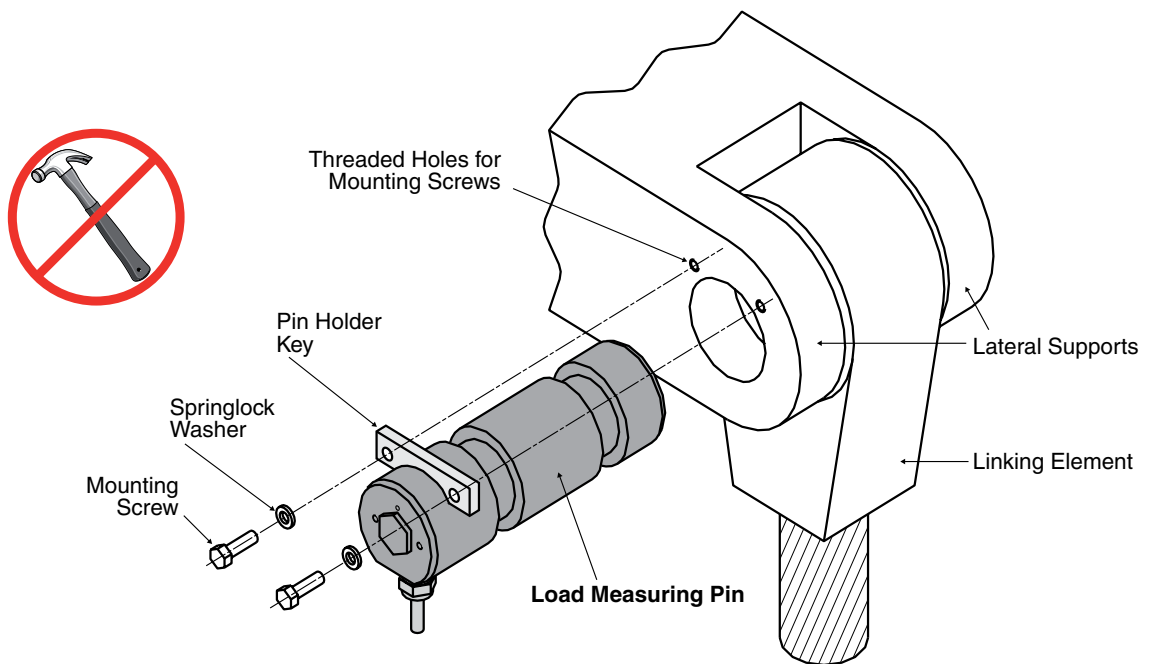

Fig.2-4 Positioning of the load measuring pin

Position the load measuring pin facing the bores in which it will be seated (see Fig.2-4). Turn it so that the mortise for receiving the pin holder key is facing upward and perpendicular to the applied force.



NOTICE

The direction of the sensitivity axis is defined by the position of holding key. This one is perpendicular to the sensitivity axis and is normally facing the force applied to the central portion (see section 4.1 - INFLUENCE OF THE LOAD PIN ORIENTATION).

**CAUTION**

THE TEST REPORT OF OUR STANDARD LOAD PINS WERE CREATED WITH THE PIN HOLDER KEY FACING UPWARDS. IF THE LOAD PIN IS INSTALLED WITH THE PIN HOLDER KEY FACING DOWNWARDS, A SLIGHT VARIATION IN THE SIGNAL WILL BE OBSERVED.

3. Manually slide the load measuring pin into its seat (*see Fig.2-4*), until the mortise for receiving the pin holder key reaches the lateral support. This inserting of the load measuring pin should be done without the use of any tool. If it is impossible to slide the pin in, check the alignment (concentricity and axially) of the elements and machine again, if necessary.
4. Insert the pin holder key into the mortise and align the key to coincide with the threaded holes for the fastening screws.
5. Place the two fastening screws, fitted with their washers, into the holes of the pin holder key (*see Fig.2-4*), and screw them into the previously threaded holes, applying the screwing torque specified in table (*see Fig.2-3*).
6. For pins equipped with lubricators (optional for LB 216 - LB 221 and LE 216 - LE 221, LE 416 - LE 421 and LE 616 - LE 621) inject lubricant (grease or oil) by means of a grease gun or oil pump.

2.2 EXTRACTION OF THE LOAD MEASURING PINS

**NOTICE**

For load measuring pins with an electrical connector it is possible to disconnect the cable in order to facilitate the extraction.

**CAUTION**

NEVER UNSCREW THE STUFFING GLAND OF A LOAD MEASURING PIN. NEVER HIT THE STUFFING GLAND OR THE ELECTRICAL CONNECTOR WITH ANY TOOL. NEVER EXTRACT THE LOAD MEASURING PIN BY PULLING AT ITS CABLE, STUFFING GLAND OR ELECTRICAL CONNECTOR.

THE WATERPROOFNESS OF THE LOAD MEASURING PIN IS NO LONGER GUARANTEED IF THIS WARNING IS NOT COMPLIED WITH.

**NOTICE**

If the load measuring pin is bonded in its seat, first rotate it around its axis by means of the screws screwed into the extraction screw threads. It is also possible to apply a derusting agent, which can prove effective in some cases.

**CAUTION**

NEVER USE THE HEXAGONAL COVERS AT THE ENDS OF THE LOAD MEASURING PINS TO ROTATE OR TO PULL THEM.

THE COVERS MAY UNSCREW. IN THAT CASE THE WATERPROOFNESS OF THE LOAD MEASURING PIN IS NO LONGER GUARANTEED AND THE ELECTRONIC CIRCUITS WITHIN THE LOAD MEASURING PIN CAN BE DAMAGED.

2.2.1 EXTRACTION OF LARGE SIZE LOAD PINS USING AN EXTRACTION DEVICE

(LB/LE 218 - 221, LB 238 - LB 241, LE 418 - LE 421 AND LE 618 - LE 621)

7. Before any attempt to extract, unload the load pin (remove tare). This should allow its easy extraction.
8. Load measuring pins LB/LE 218 - 221, LB 238 - 241, LE 418 - 421 and LE 618 - 621 are fitted with two extraction screw threads at each end (see Fig.2-5 & Fig.2-6) which should be used to fix the extraction device.

Use this thread to fix an extraction device (not provided by MAGTROL, see Fig.2-5). We recommend fixing it on the same side as the stuffing gland (LB 210, LE 4XX and LE 6XX series load pins with integrated cable) or the electric connector (LB 230, LE 2XX, LE 4XX and LE 6XX series load pin with connector) to avoid their damage if the pin is pulled out on the opposite end (see Fig.2-5).

2.2.1.1 LB SERIES LOAD MEASURING PINS

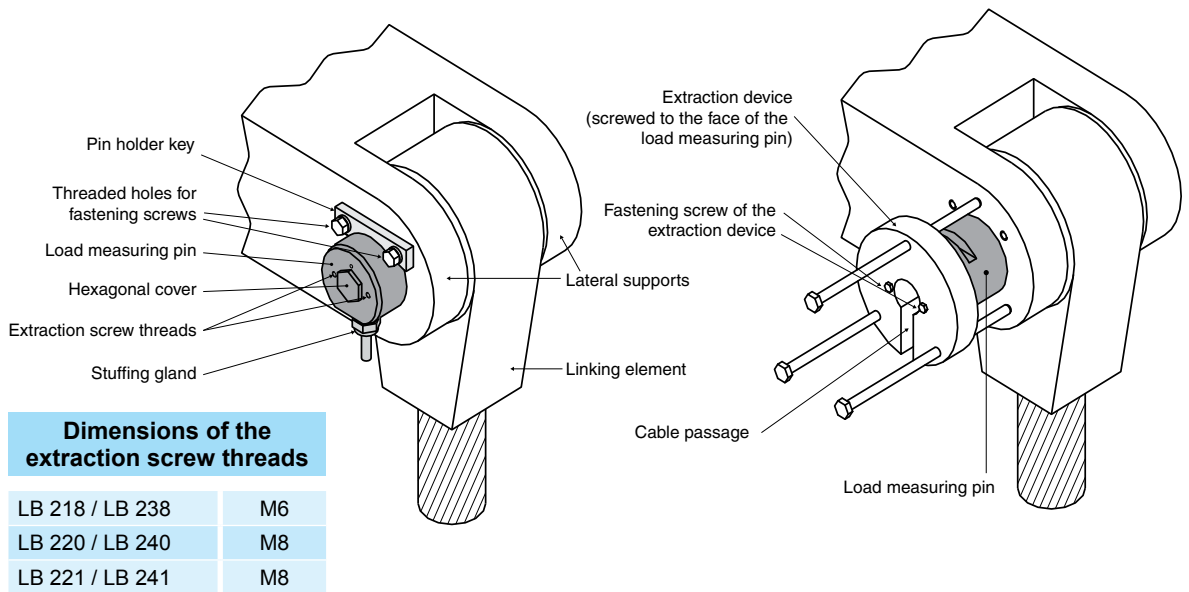

Fig.2-5 Pulling out a LB Series Load Measuring Pin by means of an extraction device

2.2.1.2 LE SERIES LOAD MEASURING PINS

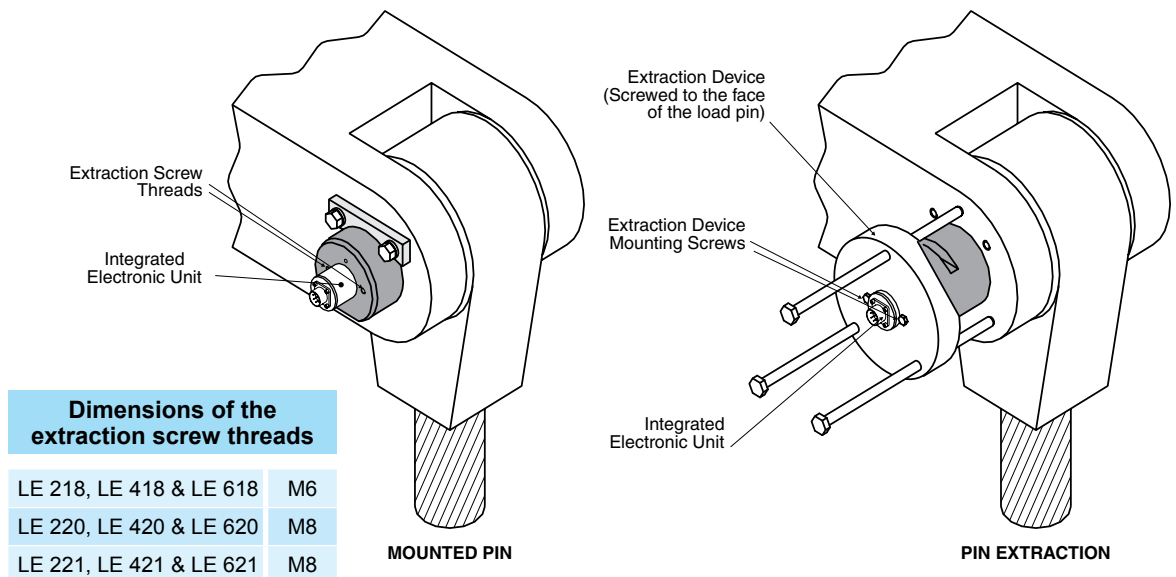

Fig.2-6 Pulling out a load measuring pin by means of an extraction device (principle used with LE 218, LE 418 and 618, LE 221, LE 421 and 621 Series Load Pins)

2.2.2 EXTRACTION OF SMALL SIZE LOAD MEASURING PINS

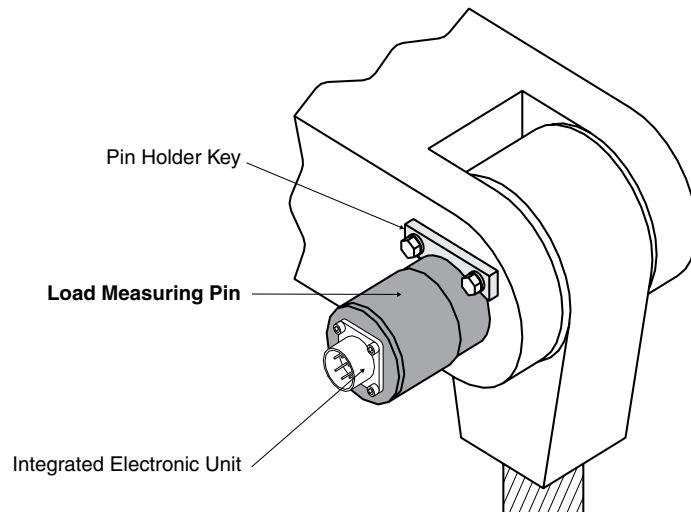
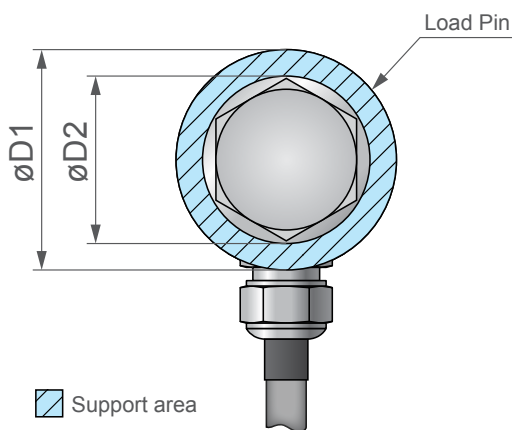

Fig.2-7 Mounted LE Series Load Pin (LE 211, LE 411 and LE 611 to LE 217 respectively . LE 417 and LE 617)

1. Before any attempt to extract, unload the load measuring pin (remove tare). This should allow its easy extraction.
2. For small size load measuring pins without extraction screw threads use a sleeve tube or a muff made of a metal of lesser stiffness than that of the pin (e.g. bronze, brass).
3. Place the tube against the pin end opposite the stuffing gland or electrical connector, taking care not to touch the hexagonal cover (see Fig.2-8).
4. Next, hit the tube with a plasticized hammer (shock absorption) to push the load measuring pin out of its seat. It is also possible to use a wooden cylinder for this operation.

2.2.3 EXTRACTION OF LOAD MEASURING PINS ON BEARINGS

For the extraction of roller bearings use an extracting device, taking care not to exert any pressure on the cover of the load measuring pin.



LOAD MEASURING PINS	D1	D2
LB/LE 214, LB 234, LE 414 & LE 614	30	26
LB 235	40	35
LB/LE 216, LB 236, LE 416 & LE 616	46	40
LB/LE 217, LB 237, LE 417 & LE 617	60	40
LB/LE 218, LB 238, LE 418 & LE 618	80	40
LB/LE 220, LB 240, LE 420 & LE 620	90	40
LB/LE 221, LB 241, LE 421 & LE 621	110	40

Fig.2-8 Support area on the end of the load measuring pin for a sleeve tube or a muff.



NOTICE

On the load measuring pins LB/LE 210 - 213, LB 231 - 233, LE 411 - 413 and LE 611 - 613 the area of support is not sufficient. Use a wooden cylinder for the extraction of the load measuring pin.

2.3 CONNECTION OF THE LOAD MEASURING PINS

Methods of connecting load measuring pins to electronic conditioning instruments supplied by Magtrol are described in this chapter. The load measuring pins can, however, also be connected to instruments from other suppliers.

A measuring and monitoring chain is composed of a transducer and an electronic signal conditioning module. For conditioning signals supplied by load measuring pins Magtrol offers a range of electronic units shown (see Fig.2-9).

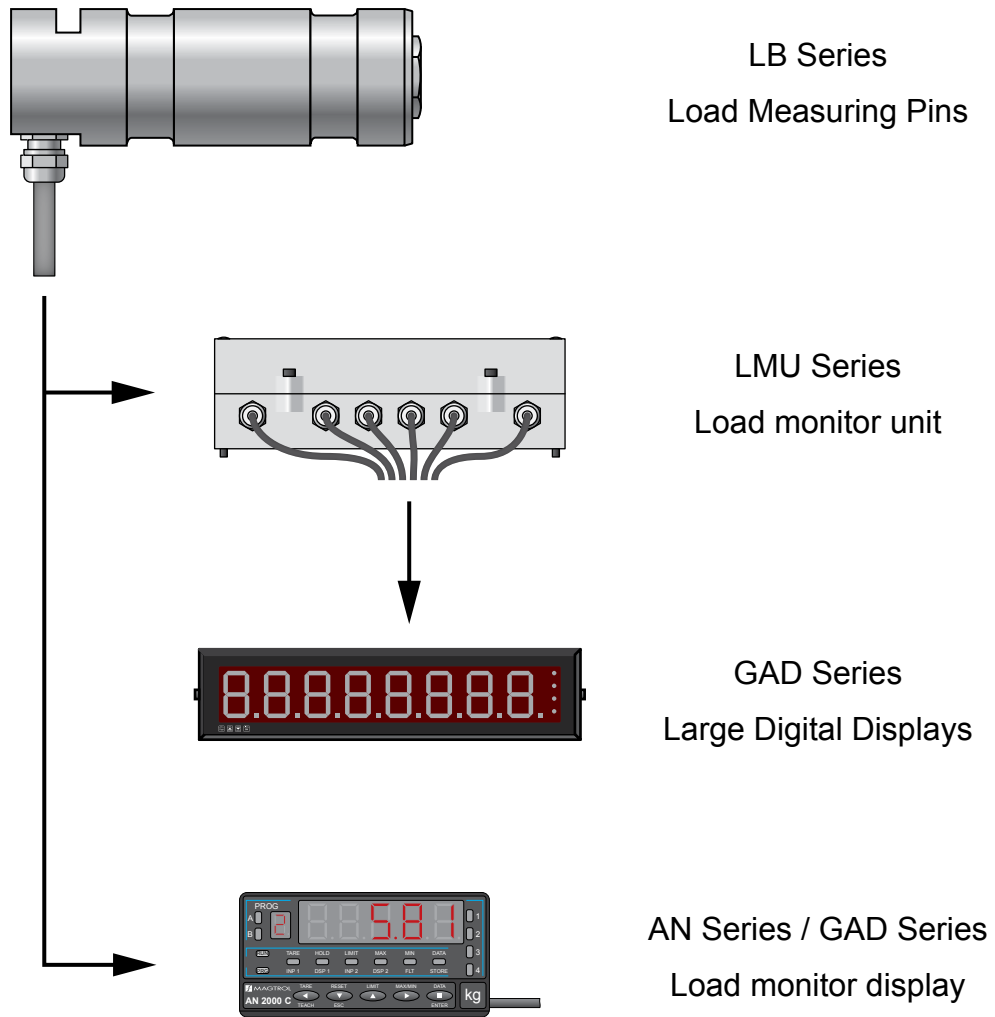

Fig.2-9 Electronic conditioning modules for connection to load measuring pins

2.3.1 CONNECTION OF A LOAD MEASURING PIN TO ANY INSTRUMENT

Connect the load measuring pin connection cable lead (see section 2.3.1.2 - Cable Connection LB Series) to the input terminal of the instrument according to the instructions given in its instruction manual.

2.3.1.1 PREVENTING MEASURING PROBLEMS

Instructions for all connection types.



CAUTION DO NOT INSTALL A CABLE NEAR A HIGH-VOLTAGE LINE. DISRUPTION OF THE MEASUREMENT SIGNAL MAY OCCUR IF THIS WARNING IS NOT COMPLIED WITH.



CAUTION CONNECT THE CABLE SCREENING TO THE EARTH AT ONE END ONLY. DISRUPTION OF THE MEASUREMENT SIGNAL DUE TO EARTH LOOPS MAY OCCUR IF THIS WARNING IS NOT COMPLIED WITH.



CAUTION IF SEVERAL SYSTEMS HAVE BEEN PRECALIBRATED, ENSURE THAT EACH AXIS IS USED WITH THE CONDITIONING ELECTRONICS WITH WHICH IT HAS BEEN CALIBRATED (REFER TO MEASUREMENT PROTOCOLS AND SERIAL NUMBERS)

OTHERWISE MEASUREMENT ERRORS COULD BE GENERATED AND A RECALIBRATION WOULD THEN BECOME NECESSARY

If it is not possible to orient the LB Series - Load Measuring Pin according to the mounting instructions given in the preceding sections, it may be mounted upside down (the mortise of the pin holder key downward). In this case, however, the sign of the signal is inverted. So that the sign is positive, two wires of the cable have to be interchanged (either those of the power supply or those of the signal), when connecting the conditioning module. In the case of inverted force, the sensitivity may be slightly altered ($\pm 1.5\%$).



NOTICE LE 2XX, LE 4XX and LE 6XX Series Load Measuring Pins cannot be mounted upside down. An inverted force would generate a negative current in the current source contained in the load pin, which is in fact impossible.

2.3.1.2 CABLE CONNECTION LB SERIES



CAUTION

BEFORE CONNECTING A LOAD MEASURING PIN TO A SIGNAL PROCESSING UNIT, MAKE SURE THAT BOTH UNITS ARE NOT RECEIVING POWER. THE CONNECTION WILL ONLY TAKE PLACE WHEN ALL THE USUAL MEASURES TO AVOID AN ELECTRIC SHOCK, WERE TAKEN.

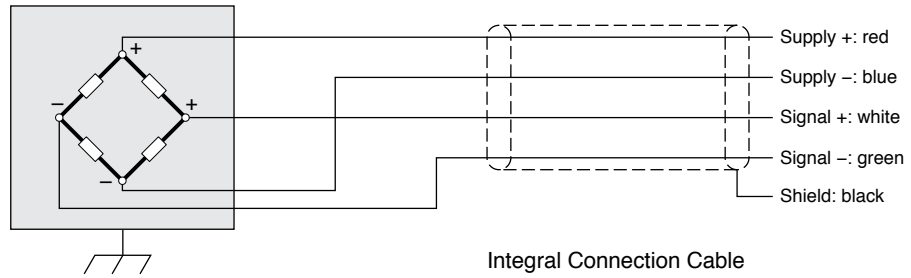

Fig.2-10 Connection of a LB 210 Series Load Measuring Pin (without connector)

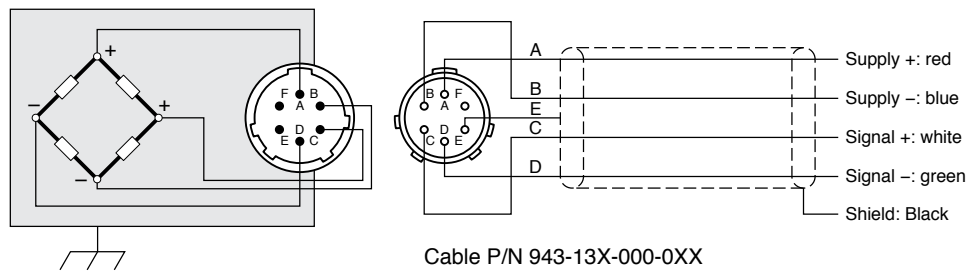

Fig.2-11 Connection of a LB 210 Series Load Measuring Pin (with connector)

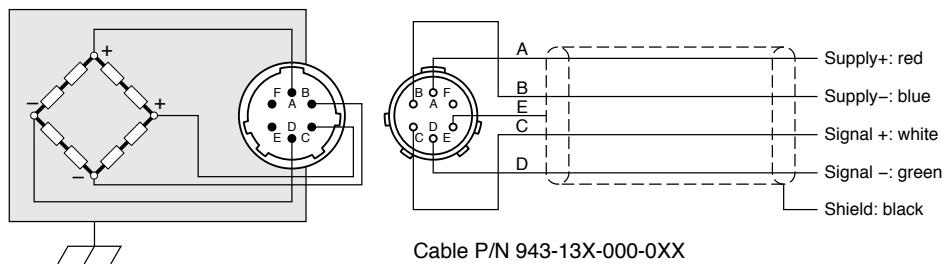

Fig.2-12 Connection of a LB 230 Series Load Measuring Pin

2.3.1.3 CABLE CONNECTION LE 2XX SERIES



CAUTION

THE MAXIMUM CURRENT CONSUMPTION OF A LOAD MEASURING PIN OF THE LE 2XX SERIES IS 25 mA. TO PREVENT ALL RISKS IN CASE OF A SHORT-CIRCUIT, IT IS ADVISABLE TO INSTALL A FUSE OR A CIRCUIT BREAKER OF 0.1 A ON THE CURRENT OUTPUT OF THE SIGNAL CONDITIONING UNIT.



NOTICE

If a programmable logic controller with built-in current limitation is used, there is no need for installing an additional device.

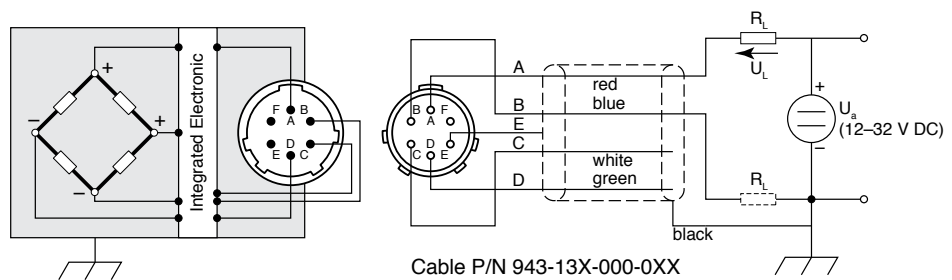

Fig.2-13 Connection of a LE 2XX Series Load Measuring Pin

2.3.1.4 CABLE CONNECTION LE 4XX SERIES



CAUTION

THE MAXIMUM CURRENT CONSUMPTION OF A LOAD MEASURING PIN OF THE LE 4XX SERIES IS 50 mA. TO PREVENT ALL RISKS IN CASE OF A SHORT-CIRCUIT, IT IS ADVISABLE TO INSTALL A FUSE OR A CIRCUIT BREAKER OF 0.1 A ON THE CURRENT OUTPUT OF THE SIGNAL CONDITIONING UNIT.



NOTICE

If a programmable logic controller with built-in current limitation is used, there is no need for installing an additional device.

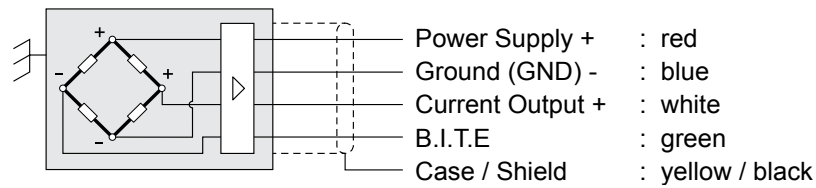

Fig.2-14 Connection of a LE 4XX Series Load Measuring Pin

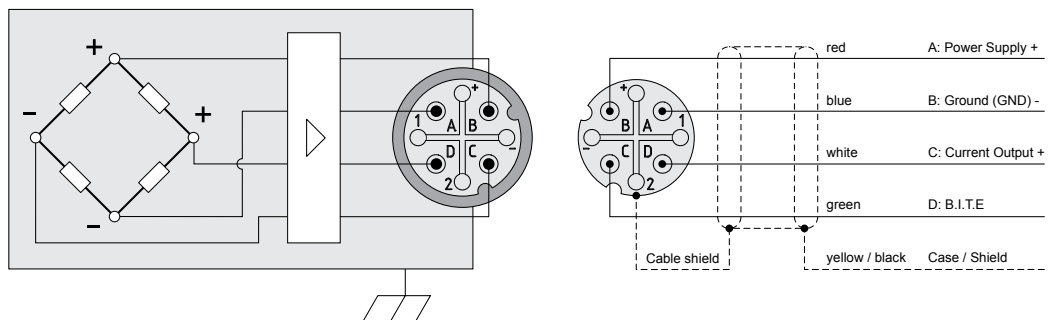

Fig.2-15 Connection of a LE 4XX Series Load Measuring Pin

2.3.1.5 CABLE CONNECTION LE 6XX SERIES



CAUTION

THE MAXIMUM CURRENT CONSUMPTION OF A LOAD MEASURING PIN OF THE LE 6XX SERIES IS 2 x 50mA. TO PREVENT ALL RISKS IN CASE OF A SHORT-CIRCUIT, IT IS ADVISABLE TO INSTALL A FUSE OR A CIRCUIT BREAKER OF 2 x 0.1 A ON THE CURRENT OUTPUT OF THE SIGNAL CONDITIONING UNIT.



NOTICE

If a programmable logic controller with built-in current limitation is used, there is no need for installing an additional device.

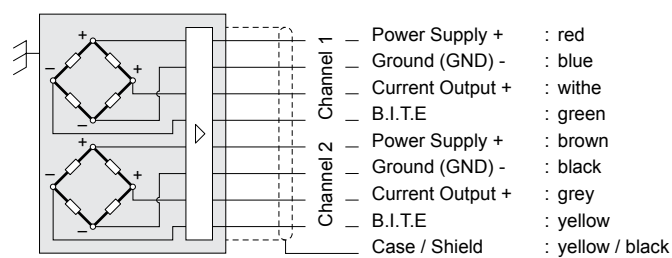

Fig.2-16 Connection of a LE 6XX Series Load Measuring Pin

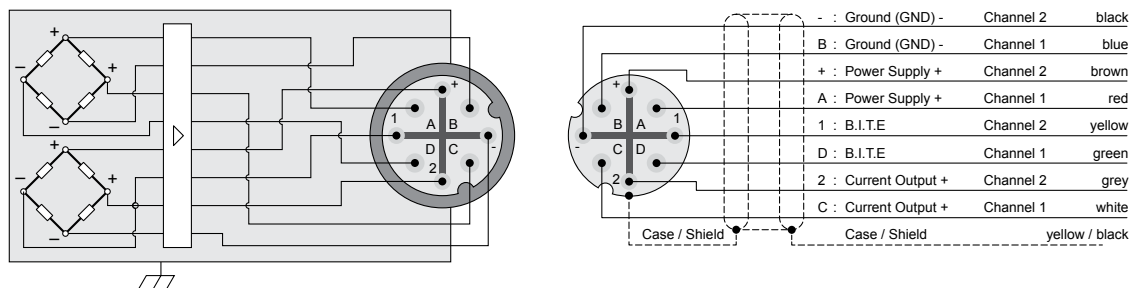

Fig.2-17 Connection of a LE 6XX Series Load Measuring Pin

2.3.1.6 DETERMINING R_L : NUMERIC EXAMPLE FOR THE LE SERIES

How to determine the load resistance R_L as a function of the supply voltage U_a ?

1. The user wants to connect the load measuring pin to a device providing a supply voltage of $24\text{VDC} \pm 10\%$.
2. Considering the defined tolerance, the supply voltage will range between 21.6VDC and 26.4VDC . Transfer the lowest value (21.6VDC) on the X-axis of the diagram. Draw from this point a vertical line to the 20mA line.
3. The intersection of this line (21.6VDC) with the 20mA determines the maximum value for the load resistance R_L (read the value on the y-coordinate). In the given example, the maximum value of the load resistance corresponds to approximately 490Ω .

$$\text{Operating range (hatched)} = \frac{\text{Load Resistance } R_L}{\text{Power Supply } U_a}$$

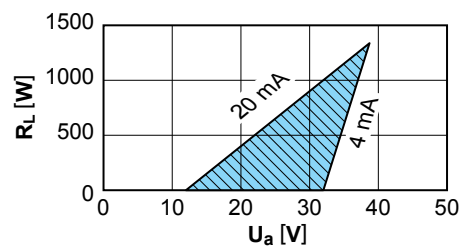

Fig.2-18 $R_L = f(U_a)$ diagram of the LE 2XX Series Load Measuring Pins operating range

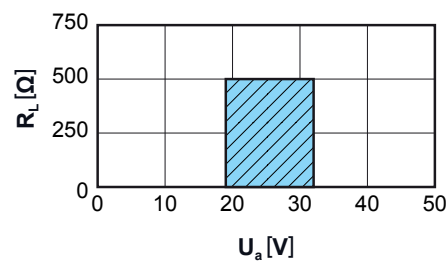

Fig.2-19 $R_L = f(U_a)$ diagram of the LE 4XX & LE 6XX Series Load Measuring Pins operating range

2.3.2 CONNECTION OF A LOAD MEASURING PIN LB SERIES TO LMU SERIES (LOAD MONITORING UNIT)

Connect the load measuring pin connection cable lead to the input terminal of the load monitoring unit according to the indications (see Fig.2-20 ... Fig.2-22). All three units, LMU 212, LMU 216 and LMU 217, have the same terminals as the LMU 216 and LMU 217 are just extensions of the LMU 212 unit.



NOTICE

For more information concerning the cabling of the LMU Series Load Monitoring Units, refer to their instruction manuals.

2.3.2.1 LB 210 SERIES & LMU LOAD MONITORING UNIT

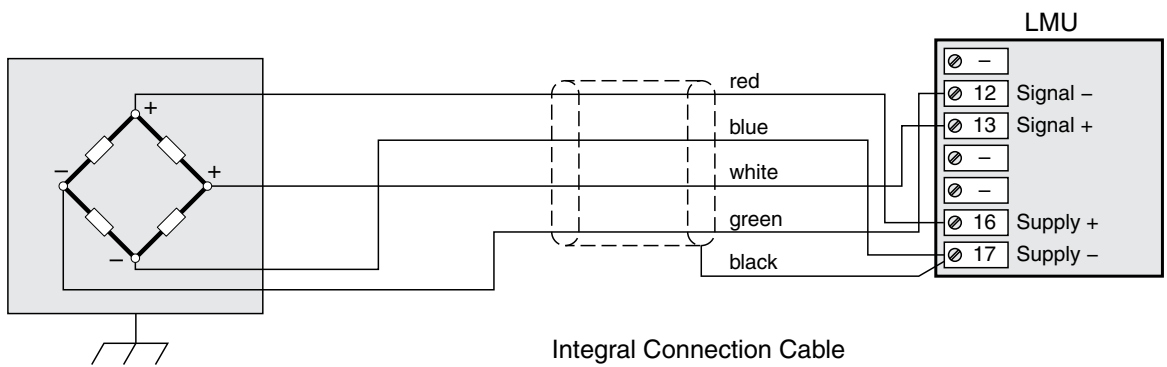

Fig.2-20 Connection of a LB 210 Series Load Pin (without connector) to a LMU Load Monitoring Unit

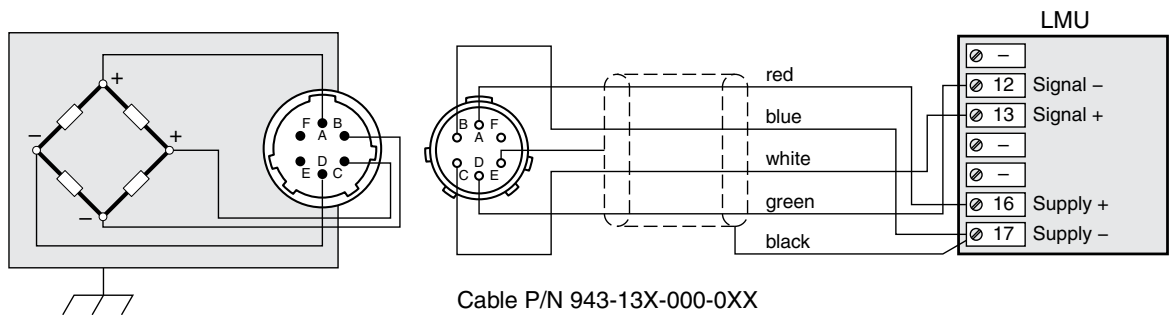

Fig.2-21 Connection of a LB 210 Series Load Pin (with connector) to a LMU Load Monitoring Unit

2.3.2.2 LB 230 SERIES & LMU LOAD MONITORING UNIT

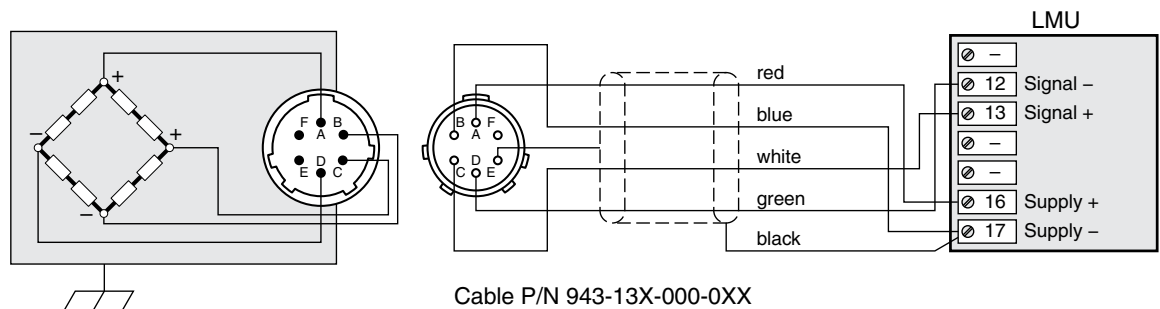

Fig.2-22 Connection of a LB 230 Series Load Pin to a LMU Load Monitoring Unit

2.3.3 CONNECTION OF A LOAD MEASURING PIN TO AN 1500 M (DIGITAL DISPLAY MONITOR)

For LB Series Load Pins, connect the load measuring pin cable to the AN 1500M input terminals as indicated (see Fig.2-24). It is also possible to connect the AN 1500 M by means of an LMU (see Fig.2-25)

For LE Series Load Pins, connect the load measuring pin cable to the AN 1500M input terminals as indicated (see Fig.2-26 ... Fig.2-28).



NOTICE

For more information concerning the cable connections of the AN 1500 M, please refer to its user manual.

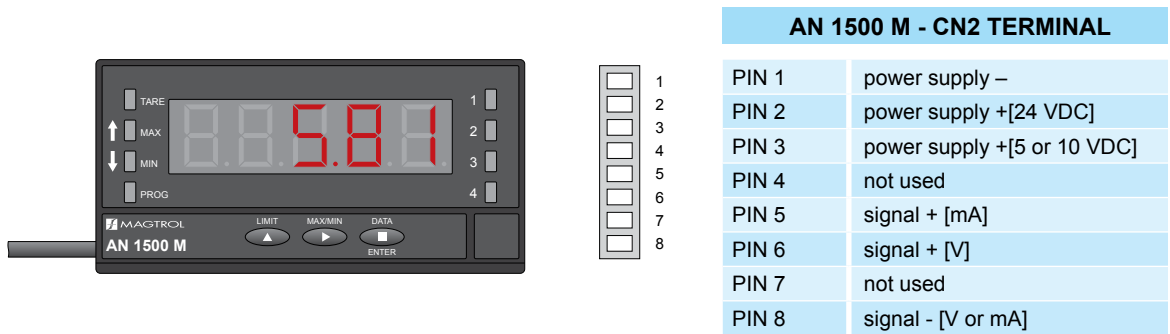

Fig.2-23 AN 1500 M with his terminal block and table of connections

2.3.3.1 LB SERIES & AN 1500 M SERIES DIGITAL SIGNAL CONDITIONER/MONITOR

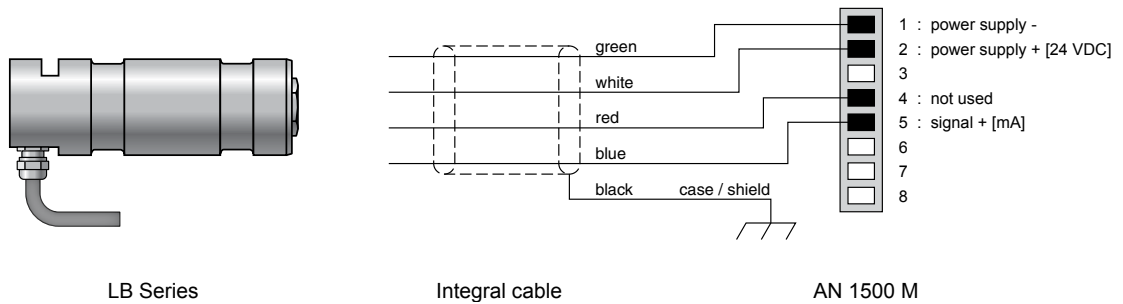

Fig.2-24 Connection of the LB Series Load Measuring Pins to an AN 1500 M

2.3.3.2 LB SERIES, LMU & AN 1500 M SERIES DIGITAL SIGNAL DISPLAY MONITOR

In the following configuration the AN 1500 M Series is used only as display

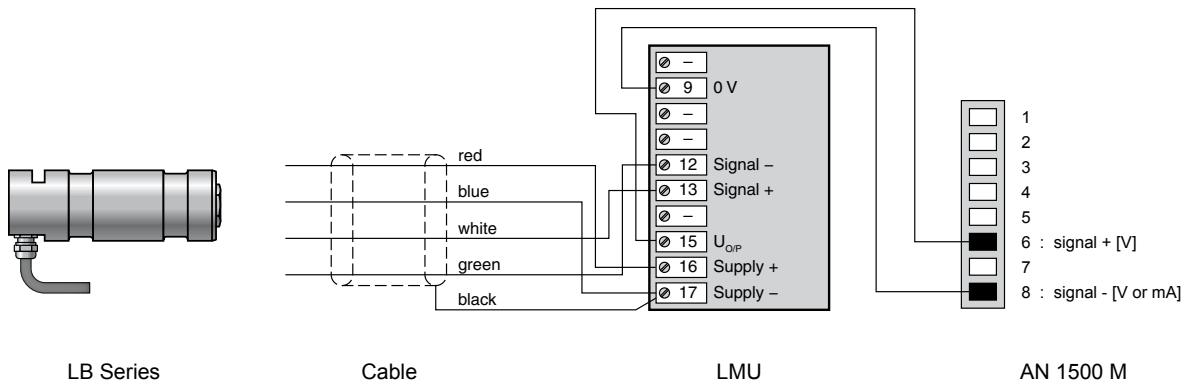

Fig.2-25 Connection of the LB Series Load Pins to an AN 1500 M through an LMU Series Load Monitoring Unit

2.3.3.3 LE 2XX SERIES & AN 1500 M SERIES DIGITAL SIGNAL DISPLAY MONITOR

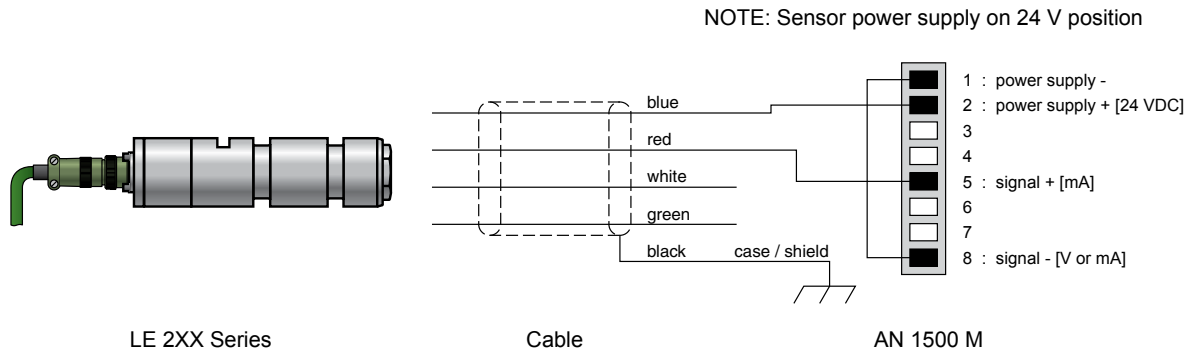

Fig.2-26 Connection of the LE 210 Series Load Measuring Pins to an AN 1500 M

2.3.3.4 LE 4XX SERIES & AN 1500 M SERIES DIGITAL SIGNAL DISPLAY MONITOR

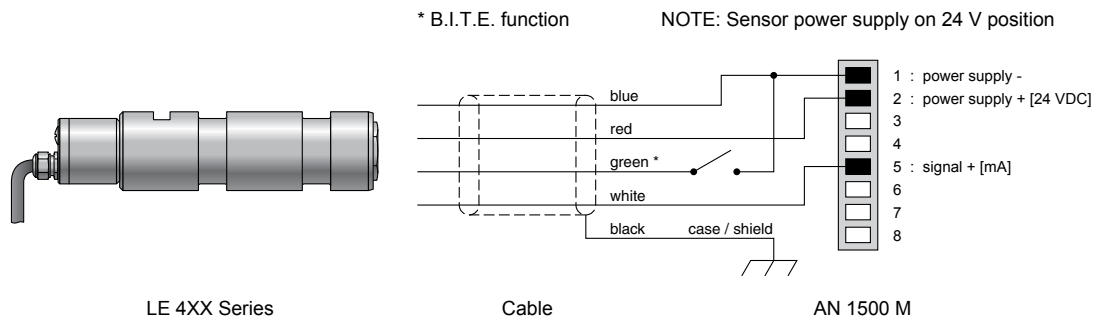

Fig.2-27 Connection of the LE 4XX Series Load Measuring Pins to an AN 1500 M

* B.I.T.E. function: please refer to **chapter 3.4**

2.3.3.5 LE 6XX SERIES & AN 1500 M SERIES DIGITAL SIGNAL DISPLAY MONITOR

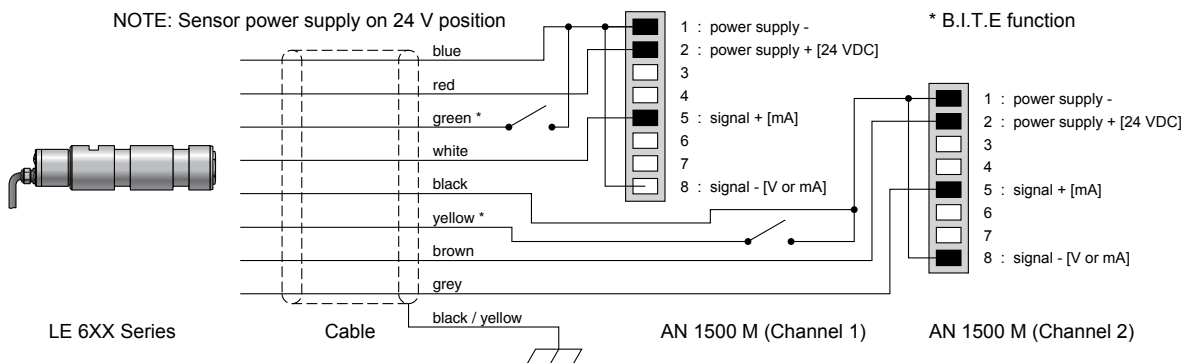

Fig.2-28 Connection of the LE 6XX Series Load Measuring Pins to an AN 1500 M

* B.I.T.E. function: please refer to **chapter 3.4**

2.3.4 CONNECTION OF A LOAD MEASURING PIN TO AN 2000 C (DIGITAL SIGNAL CONDITIONER / MONITOR)

For LB Series Load Pins, connect the load measuring pin cable to the AN 2000 C input terminals as indicated (see Fig.2-29).



NOTICE

For more information concerning the cable connections of the AN 2000 C, refer to the corresponding instruction manual.



NOTICE

The AN 2000 C has no current input. The LE 2XX, LE 4XX and LE 6XX Series Load Measuring Pins cannot be directly connected to them.

2.3.4.1 LB SERIES & AN 2000 C SERIES DIGITAL SIGNAL CONDITIONER / MONITOR

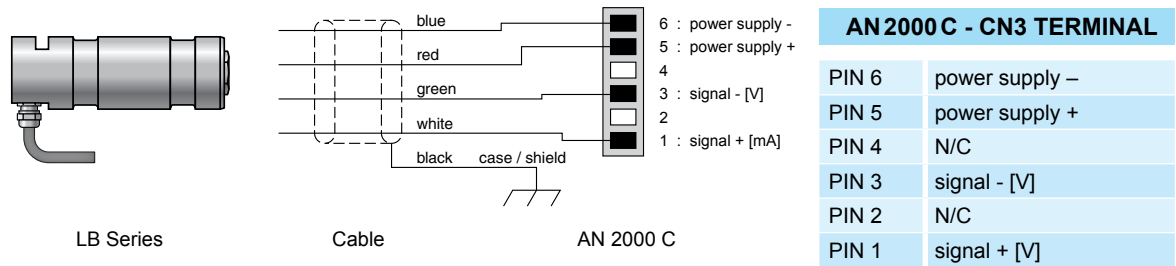

Fig.2-29 Connection of the LB Series Load Measuring Pins to an AN 2000 C

2.3.5 CONNECTION OF A LOAD MEASURING PIN TO GAD SERIES (LARGE DIGITAL DISPLAY)

For LB Series Load Pins, connect the load measuring pin cable to the GAD Series Large Digital Display input terminals as indicated (see Fig.2-30 & Fig.2-31).

For LE Series Load Pins connect the load measuring pin cable to the GAD Series Large Digital Display input terminals as indicated (see Fig.2-32 ... Fig.2-34).



NOTICE

For more information concerning the cabling of the GAD Series Large Digital Display, refer to the instruction manual.

2.3.5.1 LB SERIES, LMU & GAD SERIES LARGE DIGITAL DISPLAY

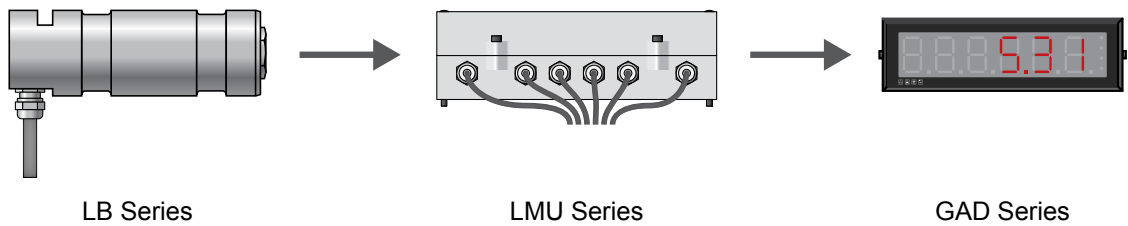

Fig.2-30 Connection of the LB Series Load Pins to a GAD through an LMU Series Load Monitoring Unit

GAD 057 - 280 : ANALOG INPUTS

PIN 1	supply +
PIN 2	signal -
PIN 3	signal [mA]
PIN 4	signal [V]
PIN 5	NC
PIN 6	supply -

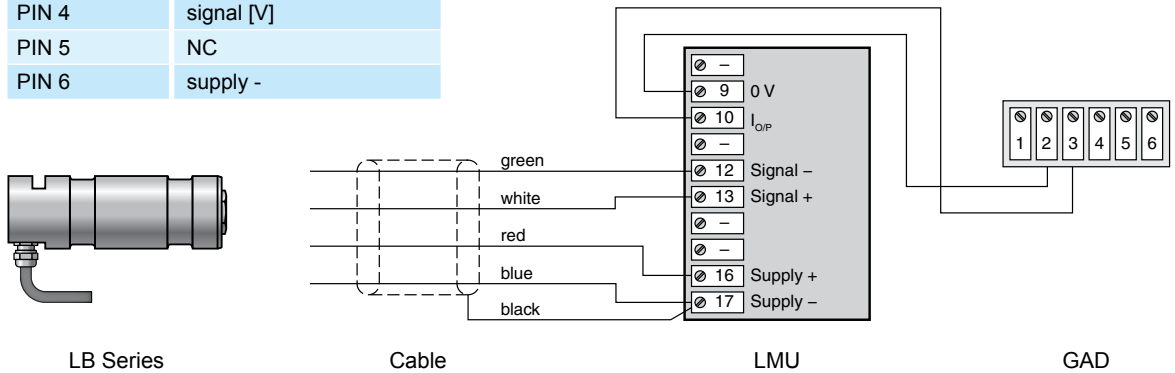

Fig.2-31 Connection of the LB Series Load Measuring Pins to a GAD through an LMU Series Load Monitoring unit

2.3.5.2 LE 2XX SERIES & GAD SERIES LARGE DIGITAL DISPLAY

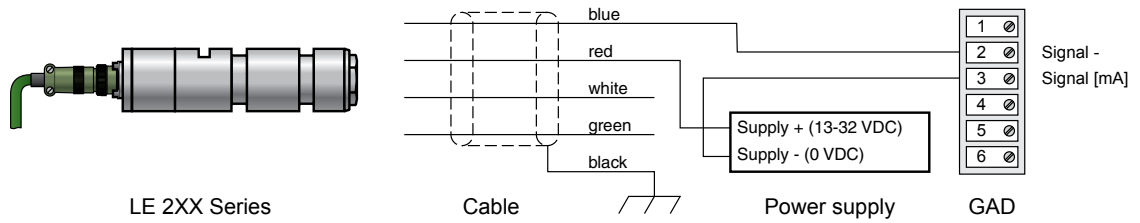

Fig.2-32 Connection of the LE 2XX Series Load Measuring Pins



CAUTION

THE POWER SUPPLY VOLTAGE MUST BE AT LEAST 13V, AND NOT ONLY 12V AS THE GAD GENERATES A VOLTAGE DROP OF 1 V.

2.3.5.3 LE 4XX SERIES & GAD SERIES LARGE DIGITAL DISPLAY

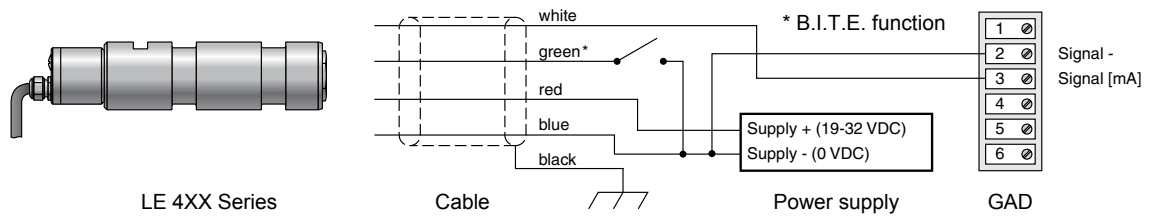

Fig.2-33 Connection of the LE 4XX Series Load Measuring Pins

* B.I.T.E function: please refer to **chapter 3.4**

2.3.5.4 LE 6XX SERIES & GAD SERIES LARGE DIGITAL DISPLAY

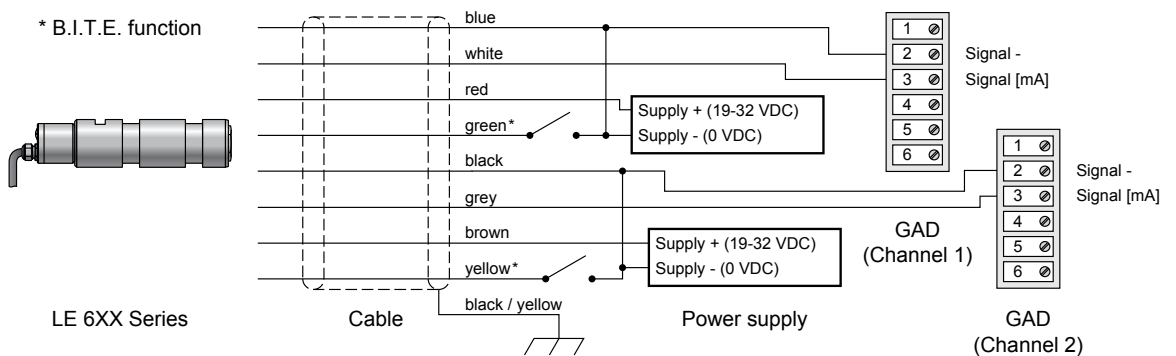

Fig.2-34 Connection of the LE 6XX Series Load Measuring Pins

* B.I.T.E function: please refer to **chapter 3.4**

3. OPERATING PRINCIPLES

3.1 MEASUREMENT PRINCIPLE

The LB 210, LB 230, LE 2XX, LE 4XX and LE 6XX Series Load Measuring Pins have the shape of a hollow cylinder. The outside diameter «A» features two circular grooves with a reduced diameter «X» (see Fig.3-1). Due to the reduced pin section, the deformations caused by the application of the force «F» on the central portion of the pin concentrate themselves on the area of both circular grooves.



NOTICE

To avoid any unnecessary redundancy, the LB 210 Series Load Measuring Pins will, if not specially specified, be used to explain the operating principle of the pins manufactured by Magtrol.

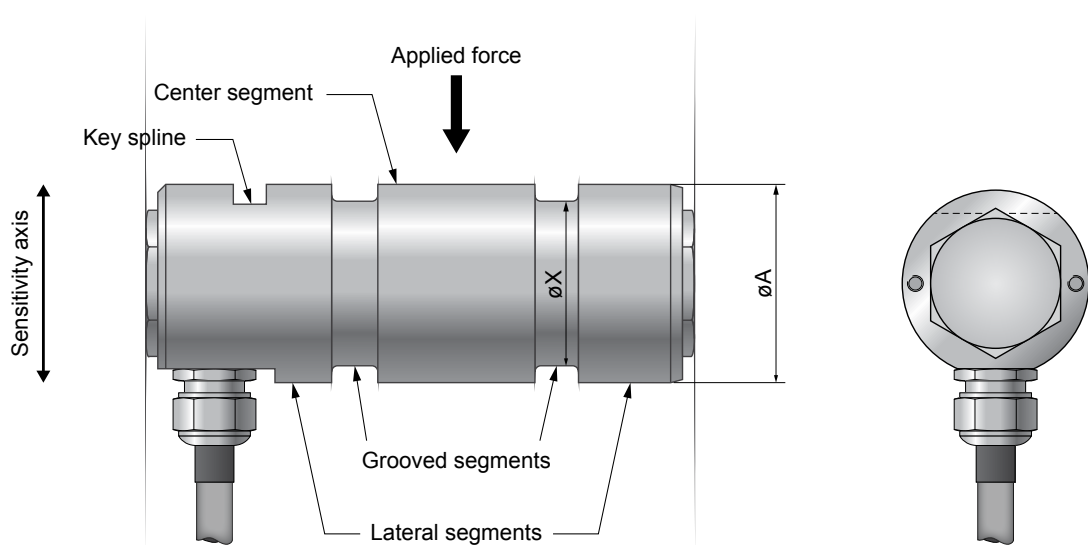

Fig.3-1 Body of the LB 210 Series Load Measuring Pin



NOTICE

The direction of the sensitivity axis can be found by means of the mortise for the pin holder key. The latter is perpendicular to the sensitivity axis and should be facing the force applied to the central portion.



CAUTION

THE TEST REPORT OF OUR STANDARD LOAD PINS WERE CREATED WITH THE PIN HOLDER KEY FACING UPWARDS. IF THE LOAD PIN IS INSTALLED WITH THE PIN HOLDER KEY FACING DOWNWARDS, A NEGATIVE SIGNAL WILL BE OBSERVED.



NOTICE

Measurements with an LE Series Load Measuring Pin mounted upside down will not work. This series has been designed to produce a positive current measurement signal.

3.2 STRAIN GAUGES

Strain gauges are placed on the inside of the load measuring pin. The strain gauges are situated symmetrically in the bore, their situation coinciding with that of the grooves visible outside.

When a load is applied to the load measuring pin in the direction of its sensitivity axis, the strain gauge full bridge produces a signal which is proportional to the load applied. For all LB Series Load Measuring Pins an external power supply for the strain gauges is necessary. The output signal processing is carried out by an external amplifier. Magtrol also offers LE Series Load Pins with an integrated strain gauge power supply and amplifier.

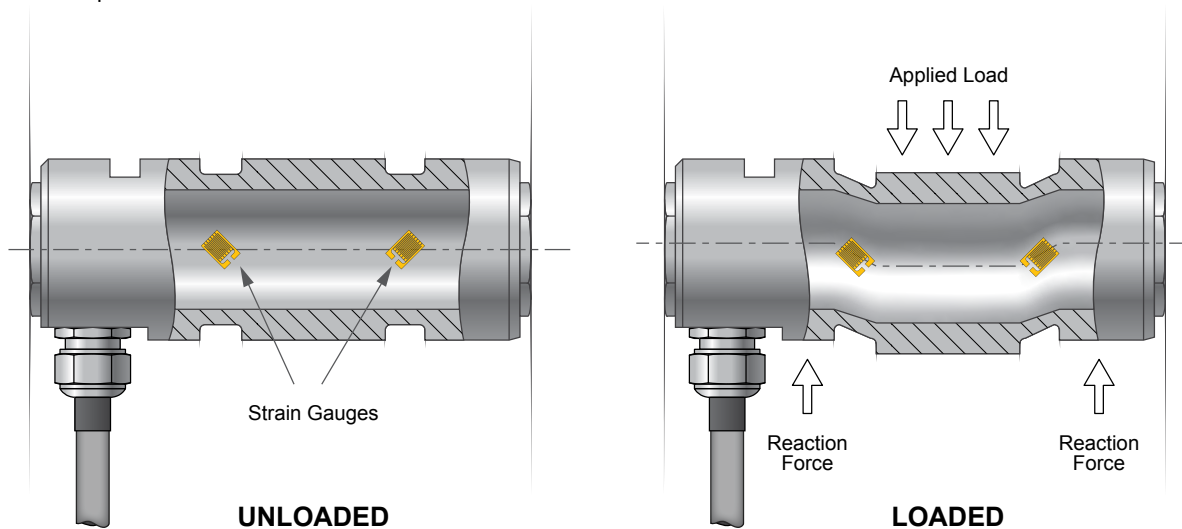

Fig.3-2 Unloaded and loaded Load Measuring Pin principle



NOTICE

With their double bridge strain gauges the LB 230 Series Load Measuring Pins are nearly insensitive to transversal or axial loads. This is equally true for excentered loads.

3.3 CHECKING OF THE APPLIED LOAD

3.3.1 LB SERIES LOAD MEASURING PINS

In order to determine or to check the load applied to an LB Series Load Measuring Pin, proceed as follows:

4. Determine the sensitivity of the load measuring pin by referring to measuring protocol delivered with the load pin under "Rated output" (for example 0,998 mV/V).
5. Measure the pin's power supply voltage generated by the signal conditioning electronic using a digital voltmeter (for example 10 VDC).
6. At rated load, the signal supplied by the load measuring pin corresponds to the sensitivity value multiplied by the supply voltage (for example 0,998 mV/V × 10 V = 9,98 mV).

For any measured signal the applied load can be easily calculated by means of the rule of three.

CHECKING EXAMPLE

Model LB SERIES

Type of load measuring pin :

Serial number :

RATED SIGNAL

$$\text{SUPPLY VOLTAGE} \times \text{SENSITIVITY} = \text{RATED SIGNAL}$$

$$\square\square.\square\square \text{ V} \times \square\square.\square\square\square \text{ mV/V} = \square\square.\square\square\square \text{ mV}$$

CALCULATED SIGNAL

$$\frac{\text{RATED SIGNAL} \times \text{APPLIED LOAD}}{\text{RATED LOAD}} = \text{RESULTE}$$

$$\frac{\square\square.\square\square\square \text{ mV} \times \square\square.\square\square\square \text{ kN}}{\square\square.\square\square\square \text{ kN}} = \square\square.\square\square\square \text{ mV}$$

MEASURED SIGNAL



NOTICE This form, which can be copied, should simplify checking the load measuring system. In the case of measurement problems it can also be sent in to the After Sales Service Department at Magtrol

3.3.2 LE SERIES LOAD MEASURING PINS

In order to determine or to check the load applied to a LE Series Load Measuring Pin, proceed as follows:

1. The signal corresponding to the rated load is equal to 16 mA (20 mA - 4 mA).
2. Calculate the signal corresponding to the applied load by means of the following formula:

$$\text{Calculated signal [mA]} = \left(\frac{\text{Rated signal [mA]} \times \text{Applied load [kN]}}{\text{Rated load [kN]}} \right) + 4 \text{ mA}$$

3. By means of a digital milliamperemeter measure the signal corresponding to the load applied.
4. Compare the values of the calculated and measured signals. The difference should not exceed 1 %.

For any measured signal the applied load can be easily calculated by means of the rule of three.

CHECKING EXAMPLE

Model LE SERIES

Type of load measuring pin :

Serial number :

CALCULATED SIGNAL

RATED SIGNAL	×	APPLIED LOAD		+ 4 mA		=	RESULTE
16.00 mA		<input style="width: 20px;" type="text"/> <input style="width: 20px;" type="text"/> <input style="width: 20px;" type="text"/> <input style="width: 20px;" type="text"/> kN	/ <input style="width: 20px;" type="text"/> <input style="width: 20px;" type="text"/> <input style="width: 20px;" type="text"/> <input style="width: 20px;" type="text"/> kN				<input style="width: 20px;" type="text"/> <input style="width: 20px;" type="text"/> <input style="width: 20px;" type="text"/> <input style="width: 20px;" type="text"/> mA

MEASURED SIGNAL

 mA



NOTICE

This form, which can be copied, should simplify checking the load measuring system. In the case of measurement problems it can also be sent in to the After Sales Service Department at Magtrol.

3.4 B.I.T.E. TEST FUNCTION FOR LE 4XX & LE 6XX SERIES

The B.I.T.E. (Built In Test Function) of the LE 4XX and LE 6XX series makes it possible to test each channel separately by simulating a load of 70% of the nominal load. To enable the B.I.T.E. function, you must connect the B.I.T.E. input to the ground and the current output of the load pin will go up to 15.2 mA (= 4 mA + 70% x 16 mA). The test signal shall be used only when there is no load acting on the load pin to avoid the indication of an incorrect load signal. It is possible to command the test signal with a Programmable Logic Controller (use PLC relay, open collector or open-drain output) or a push-button. When the B.I.T.E. test function is not needed, you should not connect it at all (see Fig.3-3 & Fig.3-4).

B.I.T.E. Connection - activated

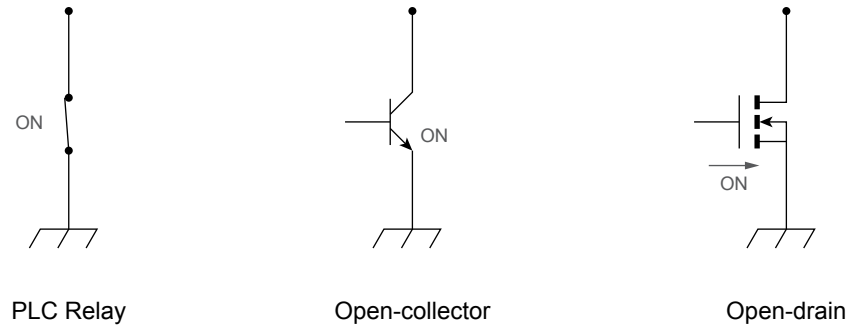

Fig.3-3 Activation of the B.I.T.E. Test Function for the LE 4XX & LE 6XX Series

B.I.T.E. Connection - disabled

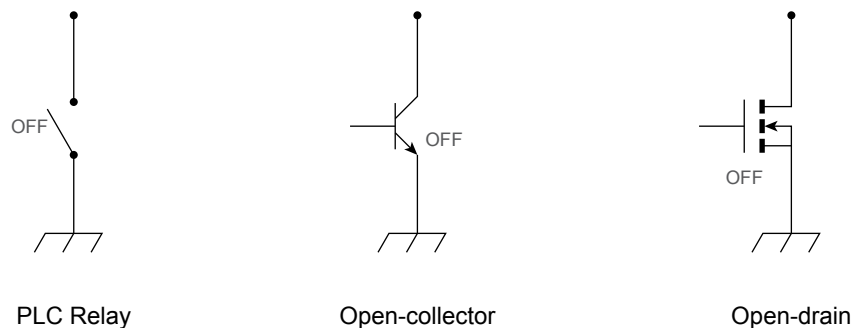

Fig.3-4 Desactivation of the B.I.T.E. Test Function for the LE 4XX & LE 6XX Series



NOTICE

Another property of the LE 4XX and LE6XX is monitoring the supply voltage permanently: if it drops below 16V, the output current shut down to 0 mA.

4. INFLUENCE FACTORS

The measurement signal delivered by the load measuring pin can be influenced by the orientation of the load pin in its seat and by possible overloads. Both topics are treated in this chapter.



NOTICE

The recommendations listed in this chapter should be followed exactly so that the load measuring pin characteristics are guaranteed.

This chapter will also demonstrate how an incorrect mounting can impair the measurement accuracy of a load measuring pin and consequently diminish the security of the whole installation.



NOTICE

Having been designed according to the EMC (Electro Magnetic Compatibility) directives, the LE Series Load Measuring Pins with integrated electronics complies with EN 61000-6-2, EN 61326-1 & EN 61326-2-3.

4.1 INFLUENCE OF THE LOAD PIN ORIENTATION

For the LB Series and LE Series Load Measuring Pins, the identification of the sensitivity axis is performed by means of the pin holder key mortise. This being by definition perpendicular to the sensitivity axis, the pin should be mounted so that it is perpendicular to the force applied on the central portion of the pin.



CAUTION

THE TEST REPORT OF OUR STANDARD LOAD PINS WERE CREATED WITH THE PIN HOLDER KEY FACING UPWARDS. IF THE LOAD PIN IS INSTALLED WITH THE PIN HOLDER KEY FACING DOWNWARDS, A SLIGHT VARIATION IN THE SIGNAL WILL BE OBSERVED.



NOTICE

A measurement with an LE 2XX, LE 4XX and LE 6XX Series Load Measuring Pin mounted upside down will not work, this series has been designed to produce a positive current measurement signal.

When the pin is not optimally positioned (see Fig.4-1 & Fig.4-2), the measurement signal will be altered accordingly, as follows:

4.1.1 LB SERIES, LOAD PINS ORIENTATION

$$U_{\text{eff}} = U_{\text{rated}} \cos \varphi$$

Where :

- U_{eff} represents the effective value of the measured signal
- U_{rated} represents the rated value of the measured signal
- φ represents the angle between the sensitivity axis of the transducer and the direction of the force applied on the central portion of the pin.

Example :

- Output signal = effective value (U_{eff}) i.e. 100 % of the full scale value.
- for $\varphi = 0^\circ$ » $\cos \varphi = 1$ » $U_{\text{eff}} = U_{\text{rated}}$
- for $\varphi = 10^\circ$ » $\cos \varphi = 0,985$ » $U_{\text{eff}} = 98,5 \% U_{\text{rated}}$

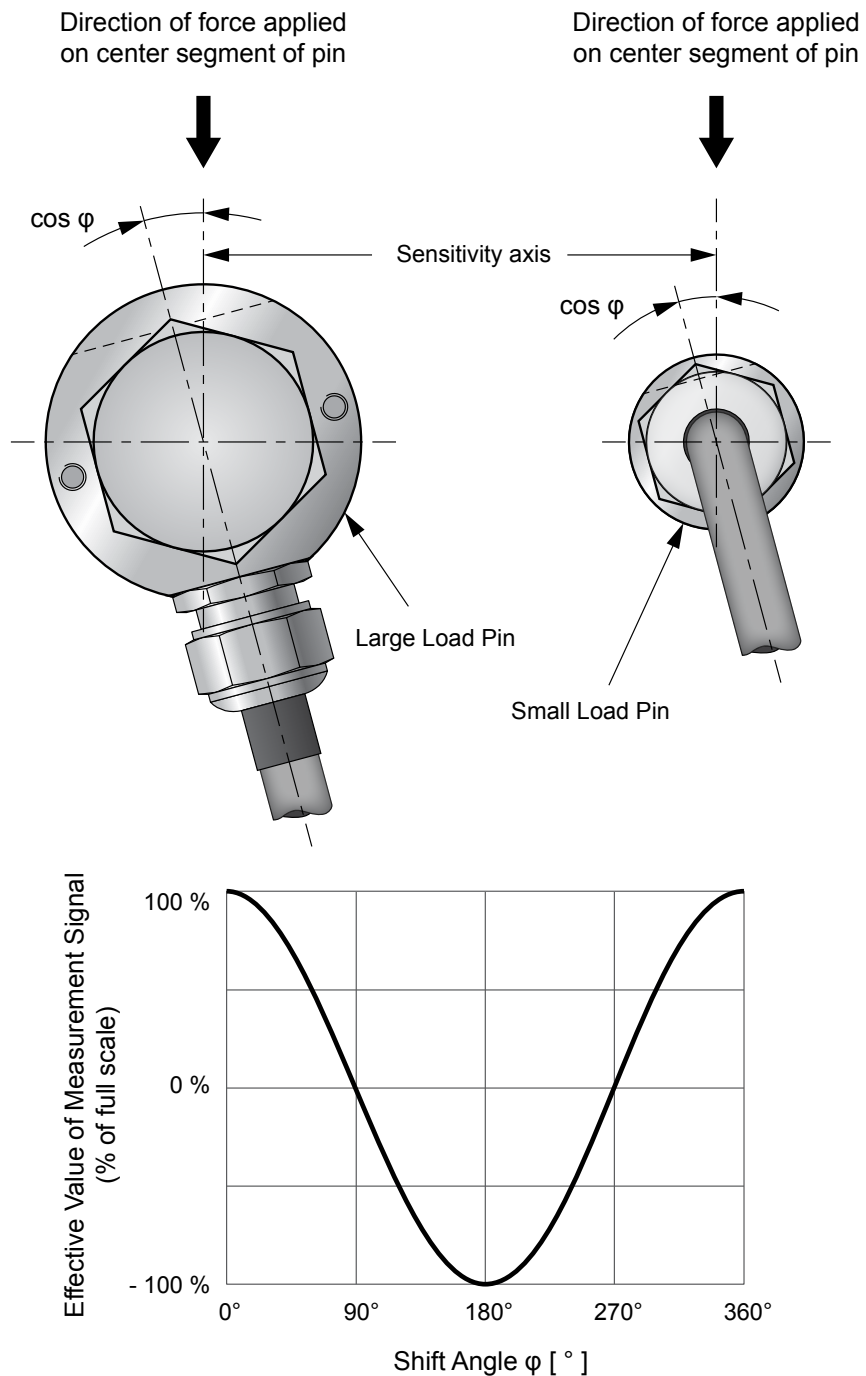

Fig.4-1 Influence of the LB Series Load Measuring Pins' orientation

4.1.2 LE SERIES, LOAD PINS ORIENTATION

$$I_{\text{eff}} = I_{\text{rated}} \cos \varphi$$

Where : I_{eff} represents the effective value of the measured signal
 I_{rated} represents the rated value of the measured signal ($I_{\text{rated}} = I_{\text{measured}} - 4 \text{ mA}$)
 φ represents the angle between the sensitivity axis of the transducer and the direction of the force applied on the central portion of the pin.

Example : Output signal = effective value (I_{eff}) i.e. 100 % of the full scale value.
 for $\varphi = 0^\circ$ » $\cos \varphi = 1$ » $I_{\text{eff}} = I_{\text{rated}}$
 for $\varphi = 15^\circ$ » $\cos \varphi = 0,966$ » $I_{\text{eff}} = 96,6 \% I_{\text{rated}}$

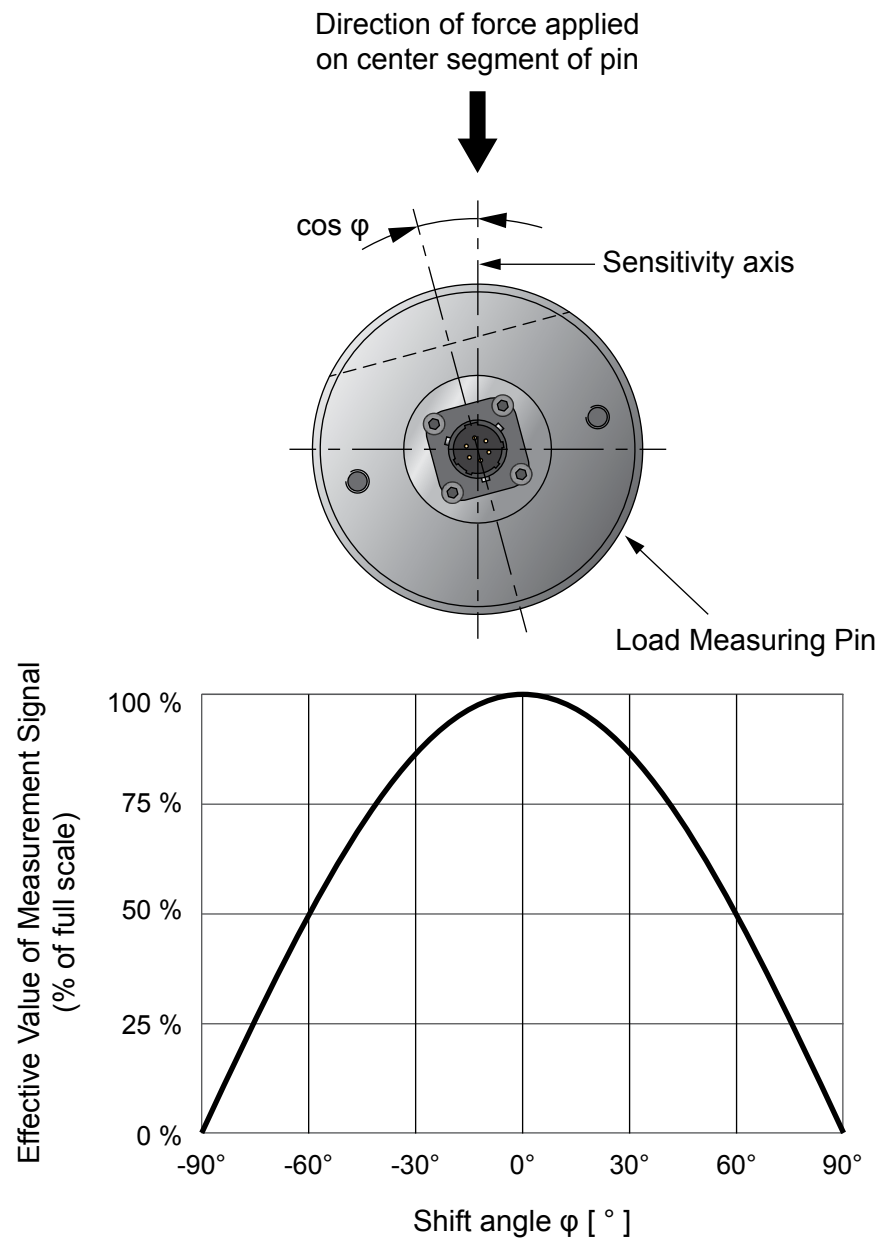

Fig.4-2 Influence of the LE 2XX, LE 4XX and LE 6XX Series Load Measuring Pins' orientation

4.2 INFLUENCE OF THE APPLIED FORCE

A load measuring pin is capable of measuring not only loads within the rated load range but loads up to 150 % of the rated load (see Fig.4-3).

However, applying loads in excess of these limits can result in permanent (plastic) deformation of the load measuring pin, or even cause it to be destroyed. In such a case, the measurement signals do not correspond to the load applied in reality. Consequently, the security of the installation and that of the user can no longer be guaranteed.

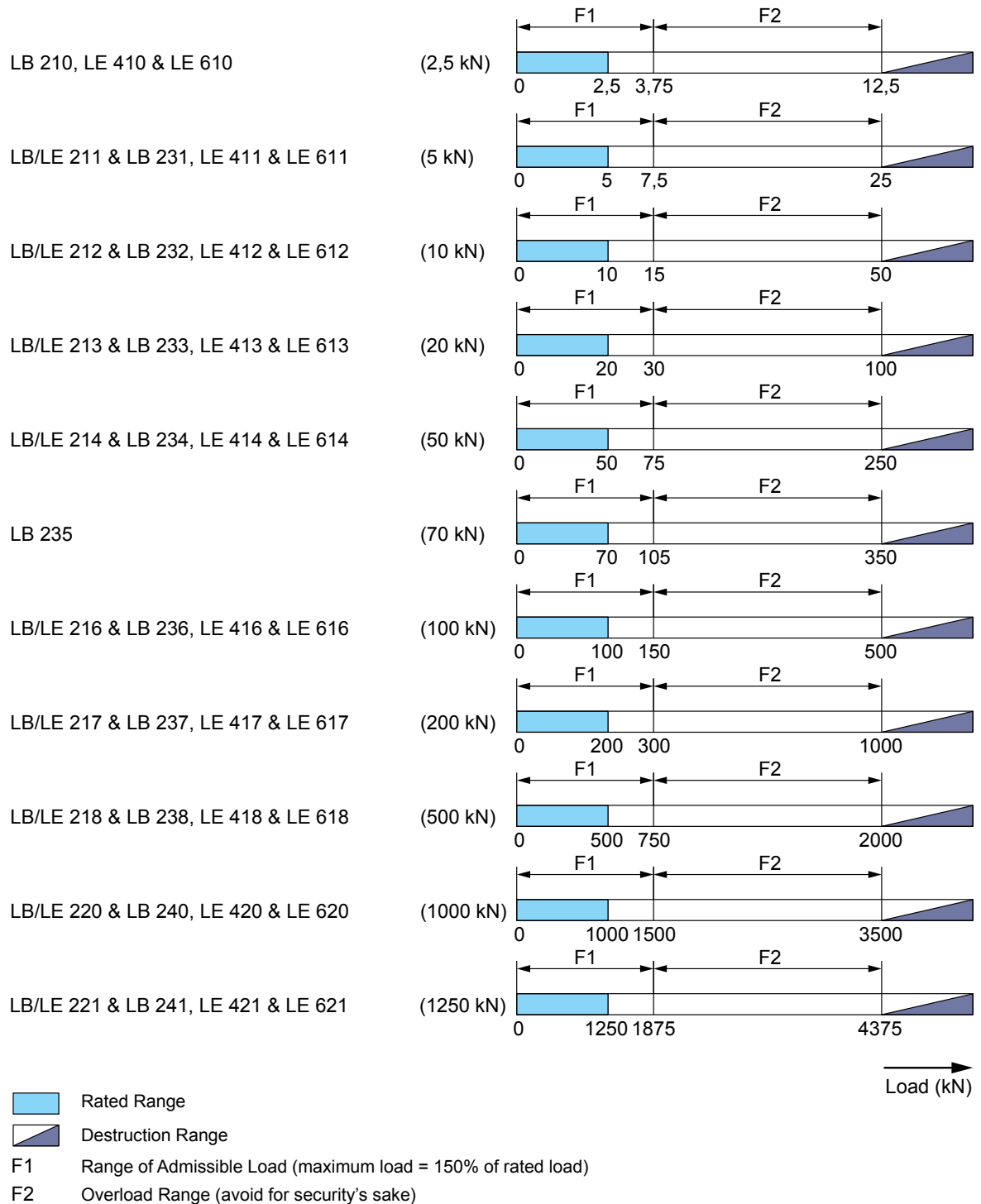

Fig.4-3 Application range of the load measuring pins.

5. MAINTENANCE, REPAIR & CALIBRATION

5.1 MAINTENANCE

Magtrol LB & LE Series Load Measuring Pins are virtually maintenance-free; this is mainly due to the simplicity of their design.

**CAUTION**

THE USER MUST NOT ATTEMPT TO CHANGE OR REPAIR ANY COMPONENTS HIMSELF. FOR ALL MAINTENANCE OR REPAIR OPERATIONS, PLEASE RETURN THE SENSOR TO MAGTROL.

SIMILARLY, THE USER SHOULD NOT ATTEMPT TO CARRY OUT REVISIONS OR REPAIRS OF ANY KIND ON THE MECHANICAL OR ELECTRONIC COMPONENTS MAKING UP THE TRANSDUCER. IF A PROBLEM IS SUSPECTED, MAGTROL SHOULD BE CONTACTED SO THAT ARRANGEMENTS CAN BE MADE TO PERFORM ANY REPAIRS IN THE FACTORY.

FAILURE TO COMPLY MAY RESULT IN SERIOUS DAMAGE TO THE TRANSDUCER OR MAY INVALIDATE THE WARRANTY.

**NOTICE**

The LB & LE Load Measuring Pins **housing is sealed**. If there is any evidence that the housing has been opened and unauthorized modifications have been attempted, **the warranty will be invalidated**.

5.1.1 LUBRICATION

All gliding surfaces of mechanical parts must be lubricated. In particular the load measuring pin must be greased before it is mounted. If the load measuring pin is used with compensation pulleys, a periodical greasing is sufficient.

When the operating conditions are particularly hostile (considerable humidity, high temperature, dust, etc), it is recommended to grease the bearings at short intervals.

For rotating pulleys mounted on gliding bearings lubrication is important. On request MAGTROL supplies load measuring pins with an incorporated device for the greasing of gliding surfaces (lubricator is an option on LB 216 - LB 221, LE 216 - LE 221, LE 416 - LE 421 and LE 616 - LE 621 Load Measuring Pins).

5.2 CALIBRATION

Recommendations for calibrating (LB 210 and LB 230 Load Measuring Pins) and the checking of measuring current for LE 2XX, LE 4XX and LE 6XX.

The most frequently encountered problems when operating load measuring pins are the detachment of the strain gauges or the plastic deformation due to an overload, as well as a torn cable during an incorrect manipulation.

The checking frequency depends on the application or on the maintenance schedule planned for the installation.

5.3 REPAIR

In case of a defect, please see chapter *see chapter SERVICES INFORMATION* of this manual. Whether you are directed to ship your equipment back to MAGTROL INC. in the United States or MAGTROL S.A. in Switzerland, it is very important to include the following information with your return shipment:

1. Model number, part number, serial number, order number and date of acquisition
2. Description of the defect and the conditions in which it appeared
3. Description of the test bench (drawing, photographs, sketches, etc.)
4. Description of the tested object (drawing, photographs, sketches, etc.)
5. Description of the test cycle



CAUTION

MAINTENANCE MUST BE PERFORMED BY MAGTROL IN ORDER TO GUARANTEE FUTURE MEASURING ACCURACY.

To allow MAGTROL to complete the work in the best possible time, carefully pack the torque transducer and follow the procedure outlined *see chapter SERVICES INFORMATION* of this manual.

6. TROUBLESHOOTING

Two different procedures are used for troubleshooting, depending on where the load measuring pin is fitted with an integrated electronics (LE Series) or not (LB Series). The following tables list a number of problems encountered with load pins and the measure to take as a remedy. It is assumed that the installation has been completed.



NOTICE

If none of the following measures show any effect, please contact your Magtrol representative.

6.1 TROUBLESHOOTING ON LB SERIES

PROBLEM	POSSIBLE CAUSE	REMEDY
No supply voltage	Broken transmission line	Check the line and the connections.
Output voltage < 0.000 V	Inversion of the applied load	Check and correct the direction of the applied load.
	Crossing of the power supply or signal cables	Check and correct the cabling.
Output voltage = 0.000 V	Broken transmission line	Check the line and the connections.
	No load	Apply a load of 20% of the rated load.
Error between measured and calculated signal	Difference between the applied effective load and the load used for calculation	Recalculate taking a possible demultiplication (pulley, lever arm, etc.).

6.2 TROUBLESHOOTING ON LE 2XX SERIES

PROBLEM	POSSIBLE CAUSE	REMEDY
Output current < 4 mA	Calibration error	Send the pin back for calibration.
	Inversion of applied load	Check and correct the direction of the applied load.
Output current = 0 mA	Broken transmission line	Check the line and the connections.
	Defect in the integrated electronics or weighing bridge	Send the pin back for checking and repair.
Output current > 20 mA	Calibration error	Send the pin back for calibration.
	Overload	Check and reduce the applied load.
Output current > 25 mA	Calibration error	Send the pin back for calibration.
	Overload	Check and reduce the applied load.
	Short-circuited transmission line	Check the line and the connections.
	Defect in the integrated electronics	Send the pin back for checking and repair.



NOTICE

The operating range of the integrated electronics is between 3.5 mA and 25 mA for all LE 2XX Series Load Measuring Pins.

6.3 TROUBLESHOOTING ON LE 4XX AND LE 6XX SERIES

PROBLEM	POSSIBLE CAUSE	REMEDY
Output current < 4 mA	Calibration error	Send the pin back for calibration
	Inversion of applied load	Check and correct the direction of the applied load.
Signal not expected > 4 mA	Calibration error	Send the pin back for calibration
	Unexpected load in the installation	Remove unwanted load or tare
Output current = 0 mA	Supply voltage below 18VDC	Increase supply voltage > 19 to 32VDC
	Broken or short-circuit transmission line	Check the line and the connections.
	Defect in the integrated electronics or weighing bridge	Send the pin back for check and repair.
B.I.T.E. enabled and output current > 15.2 mA \pm 2.4 mA	A small load is already applied on the sensor	Remove all current applied load or take it in account in your calculation.
Output current > 20 mA	Calibration error	Send the pin back for calibration
	Overload	Check and reduce the applied load.
	B.I.T.E. enabled and load applied	Check and reduce the applied load.
Output current > 25 mA	Calibration error	Send the pin back for calibration
	Overload	Check and reduce the applied load.
	Short-circuited transmission line.	Check the line and the connections.
	Defect in the integrated electronics	Send the pin back for check and repair.
	B.I.T.E. enabled and large load applied	Remove load applied when using B.I.T.E.



NOTICE

The operating range of the integrated electronics is between 0.5 mA and 22 mA for all load pins of the LE 4XX and LE 6XX Series.

APPENDIX A : OIML CERTIFICATION

Some Load Measuring Pins from the Series LB 230 (LB 334, LB 235, LB 236 and LB 237) have been certified by the OIML.

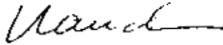
	Eidgenössisches Amt für Messwesen Office fédéral de métrologie Ufficio federale di metrologia Swiss Federal Office of Metrology	Nr. 12.2-0311
<h1>Konformitätszertifikat</h1>		
Messmittel:	Lastmessbolzen Fabrikant: Vibro-Meter AG, Fribourg Typ: LB234, LB235, LB236, LB237 OIML-Klassierung: D0.1 Höchstlast: 5000 kg, 7000 kg, 10000 kg, 20000 kg Minimale Totlast: 0 kg Grenzlast: 1.5 Mal die Höchstlast Kleinstes Eichintervall: $v_{min} = \text{Lastbereich}/100$ Konstruktion gemäss Zeichnung PZ 5876	
Antragsteller:	Vibro-Meter AG, Fribourg	
Dieses Zertifikat bestätigt die Übereinstimmung der oben genannten Typenserie mit den Anforderungen der Empfehlung der Organisation Internationale de Métrologie Légale (OIML)		
R60 "Metrological regulation for load cells" ed. 1991.		
Die Konformität mit der R60 wurde aufgrund der Resultate der Prüfungen an dem mit den übrigen Typen baugleichen Typ LB235 festgestellt. Diese Resultate sind im zugehörigen Messbericht Nr. 12.2-0283 beschrieben.		
Abteilung Mechanik, Strahlung und Thermometrie		
		
Dr. Bruno Vaucher, Abteilungschef		
Wabern, 12. März 1993 Zg		
CH-3084 Wabern, Lindenweg 50 Tel. +41 (0)31 963 31 11 Fax +41 (0)31 963 32 10 Telex 912 860 tono ch	Der Inhalt dieses Zertifikats darf nur in vollständiger Form veröffentlicht oder weitergegeben werden. La publication ou la reproduction de ce certificat n'est autorisée que dans sa forme intégrale. Il tenore di questo certificato può essere pubblicato o riprodotto soltanto integralmente. This certificate may not be published or forwarded other than in full.	
7 92 6099 B102111		

SERVICES INFORMATION

RETURNING MAGTROL EQUIPMENT FOR REPAIR AND/OR CALIBRATION

Before returning any equipment to Magtrol for repair and/or calibration, please consult the «Services» section of our web site www.magtrol.com, in order to choose the process best suited to your needs.

Depending on where the equipment is located and which unit(s) will be returned, you will be directed to either ship your equipment back to MAGTROL, Inc. in the United States or MAGTROL S.A. in Switzerland (manufacturing location).

RETURNING EQUIPMENT TO MAGTROL INC. (UNITED STATES)

When returning equipment to MAGTROL INC. in the United States for repair and/or calibration, a completed Return Material Authorization (RMA) form is required.

1. Visit the «Services/Return and Calibration» section of Magtrol's web site www.magtrol.com to initiate an RMA procedure.
2. Complete the RMA form online and submit.
3. An RMA number will be issued to you via e-mail. Include this number on all return documentation.
4. Ship your equipment to: **MAGTROL, INC.**
70 Gardenville Parkway
Buffalo, NY 14224 | USA
Attn: Repair Department
5. After Magtrol's Repair Department receives and analyzes your equipment, a quotation listing all the necessary parts and labor costs, if any, will be faxed or e-mailed to you.
6. After receiving your repair estimate, provide Magtrol with a P.O. number as soon as possible. A purchase order confirming the cost quoted is required before your equipment can be returned.

CONTACT FOR AFTER SALES SERVICE AT MAGTROL INC. (UNITED STATES)

After Sales, Repair & Calibration Services

phone +1 716 668 5555 ext. 115

fax +1 716 668 3162

e-mail service@magtrol.com

RETURNING EQUIPMENT TO MAGTROL S.A. (SWITZERLAND)

If you are directed to ship your equipment to Switzerland, no RMA form/number is required. Just send your equipment directly to MAGTROL SA in Switzerland and follow these shipment instructions:

1. Ship your equipment to: **MAGTROL S.A.**
After Sales Service
Route de Montena 77
1728 Rossens | Switzerland
VAT No: CHE-105.475.279 TVA

You can call our official carrier, TNT (account n° 154033), and return in Economy Express mode (maximum 3 days for shipments to Europe), or choose your usual carrier.

2. Include the following documents with your equipment :
 - Delivery note with Magtrol SA's address (as listed above)
 - Five (5) pro forma invoices with:
 - **Your VAT number**
 - Mention «Definitive Exportation»
 - Description of returned goods
 - **Value for customs purposes only. This value should not exceed 1000 CHF for repair units**
 - Origin of the goods (Switzerland or USA)
 - **Noticed failures or complaints**
3. A cost estimate for services will be sent to you as soon as the goods have been evaluated.
Any repair or calibration job with charges below 850 EUR / 1000 CHF / 1000 USD, will be directly serviced. You will then receive a quote that you must approve to allow the return of your material.
For all other jobs, a detailed service quote will be provided in the coming days. Please note that, for special products, the process time could be longer.
4. If you choose to not repair your equipment, Magtrol reserves the right to charge you the following fees:
 - **Return of unrepaired equipment** : 250 EUR / 300 CHF / 300 USD
 - **Disposal of the equipment** : 170 EUR / 200 CHF / 200 USD

CONTACT FOR AFTER SALES SERVICE AT MAGTROL S.A. (SWITZERLAND)

After Sales, Repair & Calibration Services

phone +41 26 407 30 00

fax +41 26 407 30 01

e-mail repair@magtrol.ch

REVISIONS TO THIS MANUAL

The contents of this manual are subject to change without prior notice. The latest updated versions of our manuals are available and downloadable at any time on Magtrol's website www.magtrol.com in the « SUPPORT » section.

To ensure that you have the latest version, compare the issue date (on the back of this manual) with the last updated document available on our website.

The table of revisions below lists the significant updates that have been made.

REVISION DATES

DATE	EDITION	CHANGE	SECTION(S)
Feb. 2021	2nd Edition - rev. D	Modifying sentence of 1st paragraphe to «When the B.I.T.E. test function is not needed, you should not connect it at all»	3.4
July 2020	2nd Edition - rev. C	Fixed an issue in illustration 3.3 & 3.4; inversion of the diagrams	3.4
June 2020	2nd Edition - rev. B	Update of the template Updated all informations concerning the LB & LE Series like datasheets,... Removing the product LU Series and all information related Removing information related to AN2000P (obsolete)	All
Aug. 2017	2nd Edition - rev. A	Updated all informations concerning the new LE-LU series; global update regarding the continuous updates. Global reorganization and new design for the manual	All
Nov. 2014	1st Edition - rev. C	Update all data sheet	1.2.1, 1.2.2, 1.2.3
July 2012	1st Edition - rev. B	Load measuring pin from LE 310 and LE 510 series added	1.1, 2.1.1, 2.1.2, 2.2.1, 2.2.2, 2.3.1.1, 2.3.1.3, 2.3.2, 2.3.3, 2.3.3.2, 2.3.4, 2.3.5, 3.1, 3.3.2, 4, 4.1, 4.1.2, 4.2, 5.1, 5.2, 6.4
April 2012	1st Edition - rev. A	Dimension L for LB 218 is now 32 mm instead of 25 mm before Dimension L for LB 220 is now 35 mm instead of 25 mm before	1.2.1

www.magtrol.com

©2021 MAGTROL | Due to continual product development, Magtrol reserves the right to modify specifications and user manual without forewarning.



MAGTROL INC

70 Gardenville Parkway
Buffalo, NY 14224 | USA
phone +1 716 668 55 55
fax +1 716 668 87 05
e-mail magtrol@magtrol.com

MAGTROL SA

Rte de Montena 77
1728 Rossens | Switzerland
phone +41 26 407 30 00
fax +41 26 407 30 01
e-mail magtrol@magtrol.ch

Subsidiaries

 Germany, France
India & China
 Worldwide Network
of Sales Agents

